

Datex-Ohmeda S/5™ Collect

User's Reference Manual

All specifications are subject to change without notice.

Document No. 8005016

March, 2003

Datex-Ohmeda Division, Instrumentarium Corporation

P.O. Box 900 FIN-00031 Datex-Ohmeda

Tel. +358 10 39411 Fax +358 9 146 3310

www.datex-ohmeda.com

© Instrumentarium Corp. All rights reserved.

Intended purpose (Indications for use)

The Datex-Ohmeda™ S/5 Collect is intended to be used as a research tool for collecting data from specified Datex-Ohmeda products. The Datex-Ohmeda S/5 Collect does not affect the intended use of these other products.

Responsibility of the manufacturer

Datex-Ohmeda Division, Instrumentarium Corporation shall in no event be liable for any direct, indirect, incidental, special, or consequential damages caused by this product.

Trademarks

Datex®, Ohmeda®, and other trademarks S/5, AS/3, and CS/3 are property of Instrumentarium Corp. or its subsidiaries. All other product and company names are property of their respective owners.

Table of contents

1 Introduction	1-1
Overview	1-1
About this manual.....	1-2
Typeface conventions	1-2
Hardware and software requirements.....	1-3
PC and interfacing	1-3
Compatible Datex-Ohmeda devices	1-3
2 Safety precautions	2-1
Notes on usage.....	2-1
3 Installation and startup	3-1
Installing S/5 Collect	3-1
Startup and registration	3-4
Loading PHY files	3-7
Exiting the S/5 Collect	3-7
4 Using S/5 Collect online	4-1
Starting the online mode	4-1
Online main window	4-3
Command buttons.....	4-4
Resizing the main window	4-4
Online waveforms	4-5
Selecting the displayed waveforms.....	4-6
Changing the waveform sampling interval	4-6
Changing the period of waveform display.....	4-8
Online trends.....	4-9
Selecting the displayed trends	4-10
Auto-selection of displayed trends	4-10
Checking the latest numerical parameter value	4-10
Changing the trend sampling interval.....	4-11
Changing the trend scale	4-11
Clearing the trends	4-12
Freezing the online trends and waveforms	4-12
Displaying alarms	4-12
Displaying events.....	4-13
Saving data in .drc files.....	4-13
Saving data in ASCII files.....	4-14
Entering and modifying notes	4-15

Taking snapshots.....	4-17
Graphical presentation of trend and waveform snapshot data	4-17
Working with graphical snapshots	4-21
Numeric presentation of trend and waveform snapshot data	4-23
Exporting snapshot data to ASCII and Excel	4-25
Using plug-ins	4-27
Printing the current window	4-28
Exiting the online mode.....	4-28

5 Using the S/5 Collect offline 5-1

Starting the offline mode.....	5-1
Offline main window	5-3
Times displayed in the offline mode	5-4
Replaying the data in offline mode	5-5
Offline waveforms	5-6
Selecting the displayed waveforms	5-7
Changing the waveform sampling interval.....	5-7
Changing the period of waveform display.....	5-7
Clearing the waveforms	5-7
Offline trends.....	5-8
Selecting the displayed trends.....	5-9
Checking the latest numerical parameter value.....	5-9
Clearing the trends	5-9
Auto-selection of displayed trends	5-9
Changing the trend sampling interval	5-10
Changing the trend scale	5-10
Showing data as XY graphs.....	5-11
Moving to a specific time in the offline graphs	5-14
Stopping an action at a desired time	5-16
Searching for markers.....	5-17
Loading PHY files	5-17
Saving data in PHY files.....	5-20
Saving data in .drc files.....	5-20
Saving data in ASCII files	5-21
Saving selected data in an ASCII file.....	5-21
Saving all data in an ASCII file.....	5-22
Viewing ASCII files	5-22
Opening a new .drc file.....	5-22
Printing	5-22
Taking snapshots.....	5-22
Notes	5-23
Using plug-ins	5-23
Exiting the offline mode.....	5-23

6 Help and troubleshooting	6-1
Getting help.....	6-1
Getting context-sensitive help	6-1
Displaying the manual	6-1
Showing registration information.....	6-2
Displaying Datex-Ohmeda web site	6-2
Showing program information	6-2
Error situations	6-2
RS232 Communication buffer indicator bar.....	6-2
Error messages	6-3
Unexpected errors	6-3
7 Editing the database configuration	7-1
Parameters.....	7-2
Waveforms	7-2
Time format for ASCII files	7-3
Defining the digit field color behavior	7-3
APPENDIX A: Using LabVIEW palettes	A-1
Plot Legend palette	A-1
Scale legend palette	A-3
Graph palette	A-5
Cursor legend palette.....	A-6
APPENDIX B: File formats	B-1
Configuration files.....	B-1
Params.txt.....	B-1
Waves.txt.....	B-6
ASCII output files	B-7
Alarms.asc.....	B-7
Waves.asc	B-11
Trends.asc	B-12
APPENDIX C: Plug-ins	C-1

1 Introduction

Overview

The Datex-Ohmeda S/5 Collect (later on also S/5 Collect) is a 32-bit LabVIEW® application designed for collecting measurement data from various Datex-Ohmeda monitoring products to a PC for analysis, for example, in Microsoft® Excel.

S/5 Collect features:

- Collects trend, waveform and alarm data directly from a monitor through a PC serial interface cable, or from a monitor in the network through the Datex-Ohmeda S/5 Central, and visualizes data online and offline for research studies.
- Allows data collection from minutes to days.
- Both online and offline data can be saved for analysis in external applications, such as Excel.
- In online mode, the collected data can be saved in `.drc` files (Datex Record Interface format) for further analysis in offline mode.
- Saving in ASCII format available in both modes.
- In offline mode, allows converting physiological data files archived by the Datex-Ohmeda S/5 Central into `.drc` format, and back.
- You can make notes and add markers during the data collection for easy analysis.
- Saves all configured settings, making it easy to manipulate the cases belonging to a research study.
- Expandable with user-designed plug-ins for LabVIEW, C++ or as DLL. For general LabVIEW interface guidelines, see appropriate LabVIEW manuals at www.ni.com.
- S/5 Collect runs under Microsoft® Windows NT® 4.0 or later, Windows® 95/98, Windows® 2000 or Windows® XP.

Please read the section "[Safety precautions](#)" before using the product.

About this manual

This manual provides instructions for installing, registering and using the Datex-Ohmeda S/5 Collect.

The manual can be found in .pdf format on the product CD-ROM in the directory \Documents. This directory also contains a readme.txt file.

Typeface conventions

To help you find and interpret information easily, the manual uses consistent text formats for certain text types:

- Command buttons are written in the following way: **Cancel**.
- Keyboard key names are written in the following way: Esc.
- Menu commands and names of dialog box parts (text boxes, list boxes, checkboxes) are written in bold italic typeface: ***Location***.
- Menu access is described from top to bottom. For example, the selection of the menu command ***Waves*** in the ***Snapshot*** menu would be shown as ***Snapshot - Waves***.
- File names, file paths and commands are written in the following way:
`comm.exe`.
- Messages displayed on the screen are written inside single quotes:
'Learning'.
- When referring to different sections in this manual or to other manuals, section names and manual names are enclosed in double quotes:
See section "Introduction."
Please refer to "Datex-Ohmeda S/5 Critical Care Monitor User's Reference Manual: Introduction."
- Cautions are displayed in the following way:

CAUTION Use only specified Datex-Ohmeda interface cables.

- Warnings are displayed in the following way:

WARNING **When you connect other equipment to the monitor, always make sure that the whole combination complies with the international safety standard IEC 60601-1-1 for medical electrical systems and with the requirements of local authorities.**

Hardware and software requirements

PC and interfacing

- IBM compatible 486 or Pentium PC with a minimum of 48 MB of memory.
- At least 20 MB free disk space.
- Microsoft® Windows NT® 4.0 or later, Windows® 95/98, Windows® 2000 or Windows® XP.
Use Windows NT or Windows 2000 when using network communication to S/5 Centrals.
- Screen settings: default small font size.
- For serial communication PC serial interface cable, order code 881167.
- For network communication, a normal network cable or a cross-over cable (depending on how the Collect PC will be connected to the network).

Compatible Datex-Ohmeda devices

The S/5 Collect is compatible with the following Datex-Ohmeda devices:

- AS/3™, CS/3™ and S/5™ monitors
- Light monitor
- Cardiocap 5™
- In case the Collect PC will be connected to the network, Central software S-CNET02, version 2.2 or higher, is required.

NOTE: AS/3 and Light monitor software released before 1998 are not able to send more than one waveform at a time.

NOTE: AS/3 software released before 1995 does not work with S/5 Collect.

2 Safety precautions

WARNING When you connect other equipment to the monitor, always make sure that the whole combination complies with the international safety standard IEC 60601-1-1 for medical electrical systems and with the requirements of local authorities.

Connecting the power supply cord of the PC to the wall socket may cause the leakage current in the system to exceed the limit specified for medical equipment. The PC shall be supplied from an additional transformer providing at least basic isolation (isolating or separating transformer).

The RS232 cable connects the PC to the monitor, and therefore indirectly to the patient.

If you are not sure whether the safety of the system is as required, please contact your local technical service personnel.

CAUTION Use only specified Datex-Ohmeda interface cables.

CAUTION Prevent accidental disconnection of all cables connected to the S/5 Collect PC.

Notes on usage

- We recommend you use the PC with battery power.
- COM1 is used as a default port in the application settings for serial communication. We recommend you use this port.

3 Installation and startup

The S/5 Collect is shipped on a CD-ROM. The installation program copies all the files that make up the application package in a directory of your choice.

NOTE: If you have ordered software license L-COLLECT 4, the CD-ROM contains four program licenses. You can get up to 4 four passwords, and use the application on 4 PCs.

Installing S/5 Collect

NOTE: Before installing, close other Windows programs.

1. Insert the S/5 Collect CD-ROM in the CD-ROM drive.
2. Select **Start - Run** and locate the `setup.exe` on the CD-ROM. Run the `setup.exe`. Click **Next** to continue.



Figure 3-1 Welcome to installation window

If you have version 4.0 already installed on your PC, the setup will first uninstall the program from its current directory after which the setup program must be started again to reinstall the S/5 Collect program.

NOTE: If you have version 3.0 installed on your PC, this does not apply. Version 3.0 can still be used on the same PC if run from another subdirectory.

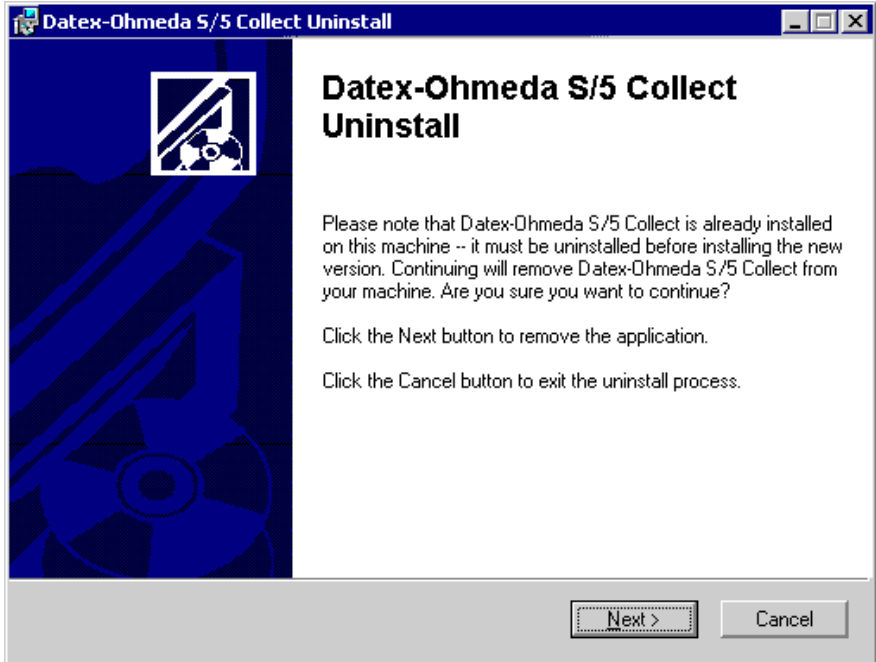

Figure 3-2 Uninstall window

3. If necessary, change the directory using **Browse**. Click **Next** to continue.

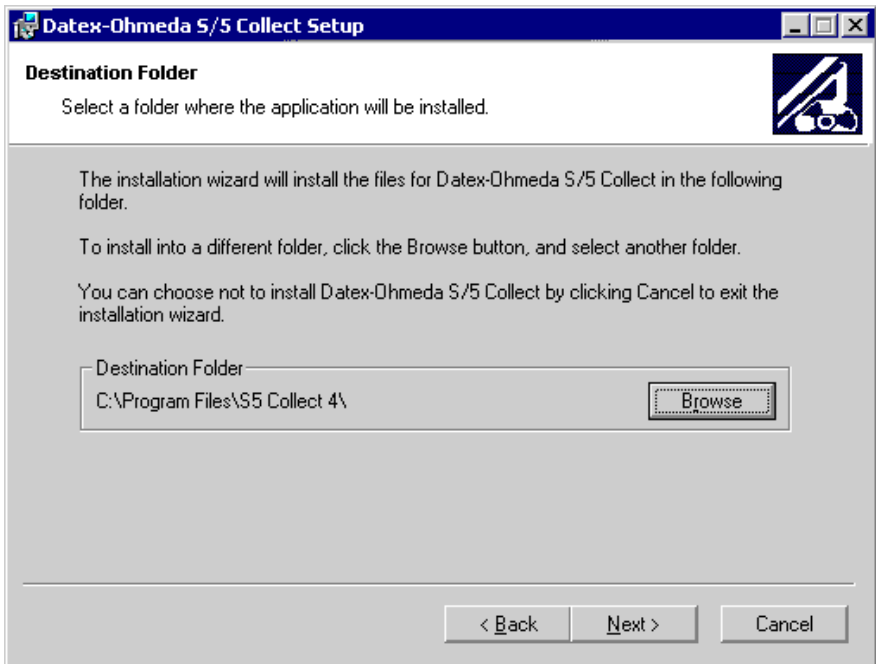

Figure 3-3 Setup window

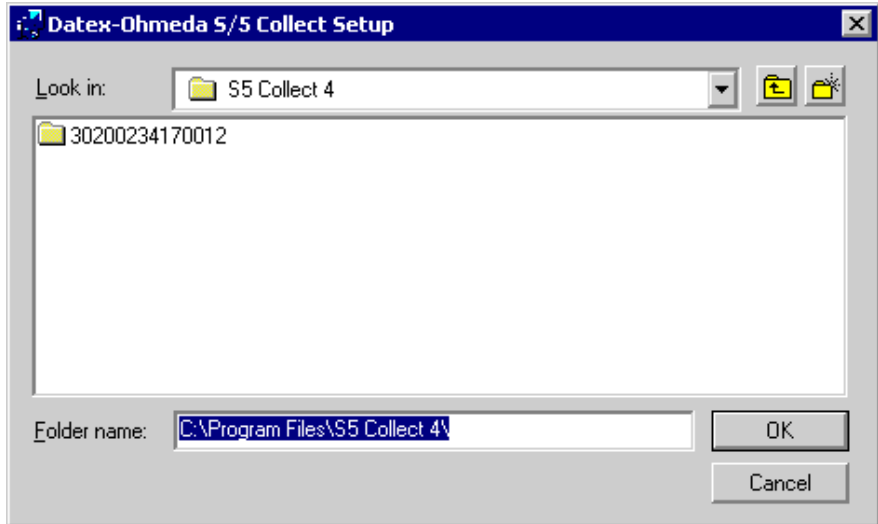

Figure 3-4 Changing the directory

4. The installation starts. If there are applications open, you get the following prompt. Close the application and select **Retry** to continue.

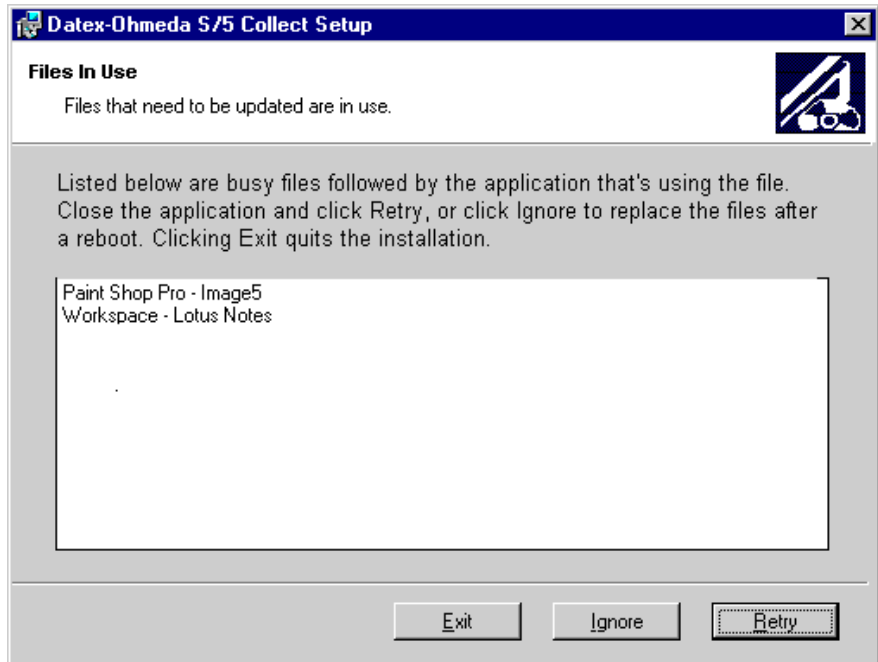

Figure 3-5 Files in use window

5. Click **Finish** to complete the installation. You are prompted to restart your computer. You can click **No** to continue to continue without restarting.

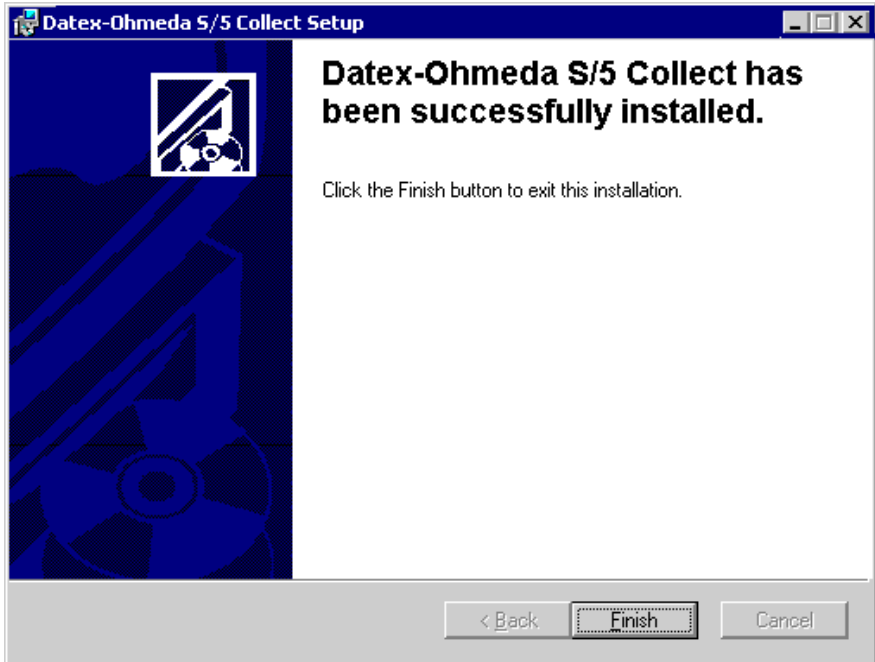

Figure 3-6 Successful installation

The S/5 Collect entry is added in the **Start** menu. The installation program automatically installs also the LabVIEW runtime engine.

You can also access this manual in .pdf format and the readme file through the **Start** menu.

Startup and registration

1. Select **Start - Programs - S5 Collect - S5 Collect**. The startup window is displayed.

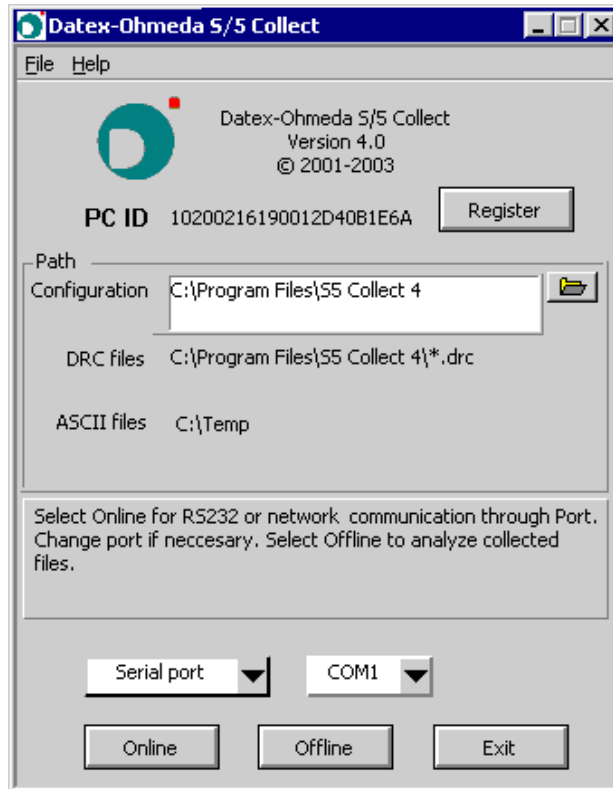

Figure 3-7 Startup window

NOTE: In the startup window, you can define the path for storing the trend and wave configuration files. This enables the use of several configurations for several research projects on one PC. Each new configuration starts with the default configuration files.

Also the paths for the latest saved ASCII file (.asc) and Datex Record Interface file (.drc) are shown.

2. The **Register** button is displayed in the startup window if you have not yet registered the application.
In online mode, to be able to save data in ASCII format, you need to send a registration and get a password. In offline mode, unregistered applications can save only 4 lines of trend data or 10 seconds of waveform data to ASCII files. In both modes, saving snapshots as .bmp, .jpeg and .png files is not supported if you are not registered.

Go to registering by clicking **Register**.

If you already have registered, continue to step 6.

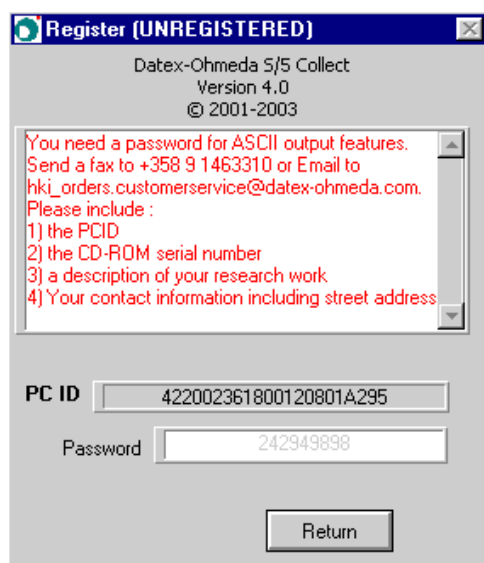

Figure 3-8 Register dialog box

3. Get a password by sending an email or fax including the displayed PC ID and all the other information requested in the Register dialog box.
 NOTE: You can use the S/5 Collect 4 on up to four PCs. To do this, register each PC separately by sending the information requested in the Register dialog for each PC. The password is connected to the PC ID, and cannot be used on another PC. You can first register one PC, and at a later date (but within a period of 3 years) register the other PCs.
 NOTE: Do not delete or change names of subdirectories in the installation directory of S/5 Collect. If the S/5 Collect directory and its subdirectories are, for some reason, deleted from the hard disk, the software must be registered again.
4. After receiving a password, enter it in the **Password** box. If the password is correct, the window will disappear automatically.
 NOTE: If you do not have a password, you may evaluate the application, but every now and then a reminder to register will be displayed.
5. The license window is displayed. Select the **I agree with all terms** checkbox and click **Continue**.
 NOTE: If you do not select the **I agree with all terms** checkbox, the application will not accept your registration.
6. From the startup window, select **Online** or **Offline**.

When the program is started, the settings in the configuration file `S5Collect.ini` are read. This file is always saved when the program exits.

Loading PHY files

You can access data that has been stored by the S/5 Central, and data on a PCMCIA card that has been used in the M-MEM module. For further information see "[Loading PHY files](#)" on page 5-17.

Exiting the S/5 Collect

In the main window, select **File - Exit** (Ctrl+Q). The S/5 Collect startup window is displayed. Click **Exit** to exit the program.

4 Using S/5 Collect online

Starting the online mode

1. Connect the S/5 Collect PC to the monitor through serial communication port or to the network through Datex-Ohmeda S/5 Central.

If you use serial communication, do as follows:

- Connect the serial cable between the monitor and the PC. The monitor should not be on while connecting the serial cable to the monitor.
- In the startup window, select **Serial port** and the name of the port (**COM1 - COM6**). **COM1** is used as a default.

NOTE: Make sure that the serial cable is properly connected. If it is not properly connected, or a wrong COM port is selected the message 'Communication Timeout' will be displayed.

If you connect to a monitor through a Central, do as follows:

- If the Central is connected to the TCP/IP network, connect the Collect PC to the TCP/IP network with a normal network cable. If the Central is **not** connected to the TCP/IP network, connect the Collect PC to the TCP/IP network board of the Central with a cross-over cable.
- Specify the IP Address (192.168.1.56) and the Subnet Mask (255.255.255.0) of the Collect PC:
 - In Windows NT environment, right-click the Network Neighborhood icon, select **Properties**, go to the **Protocols** tab and click the **Properties** button to specify the IP Address and the Subnet Mask.
 - In Windows 2000 environment, select **Start - Settings- Network and Dial-up Connections** and double-click the **Local Area Connection** icon. Then click the **Properties** button, select Internet Protocol (TCP/IP) and click the **Properties** button to specify the IP Address and the Subnet Mask.
- For each additional Collect PC in the system, add 1 to the last number of the IP address, so the second PC will be 192.168.1.57, the third 192.168.1.58 and the fourth 192.168.1.59. The total amount of the S/5 Collect PCs connected in the system may not exceed 4.

- After specifying the IP Address and the Subnet Mask, restart the Collect PC if prompted.
 - Verify that the Collect PC is connected to the Central by pinging the Central from the DOS prompt by entering command `Ping` and the Computer Name of the Central.
 - In Windows NT environment, select **Start - Programs - Command Prompt** to access the DOS prompt.
 - In Windows 2000 environment, select **Start - Programs - Accessories - Command Prompt** to access the DOS prompt.
 - In the Collect startup window, select **Network Server** and enter the Computer Name of the Central to connect to. If you have more than one Central in your system, separate the Computer Names with a space or a semicolon (;).
2. Click **Online** in the startup window. After a while, the Monitor selection dialog is displayed. Select the monitor.

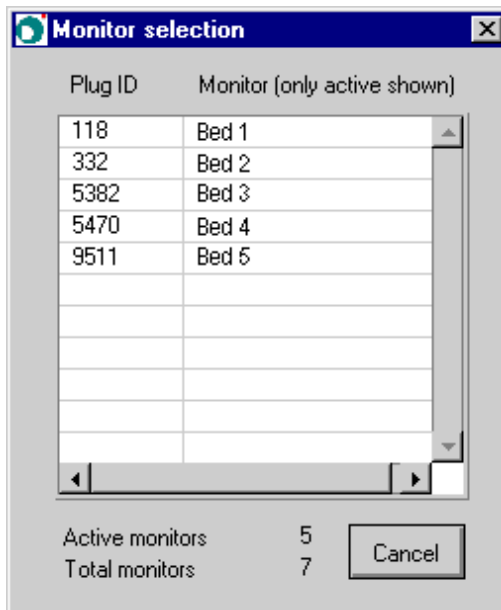

Figure 4-1 Monitor selection dialog

3. The program displays the main window and starts reading the data from the selected monitor.

Online main window



Figure 4-2 Online main window parts

- (1) Tab pages for selecting of trends and waves
- (2) Command buttons
- (3) Message area
- (4) Available free disk space
- (5) Path and name of the latest .drc or ASCII file saved
- (6) Data rate in kB.
- (7) A communication buffer indicator is displayed for serial communication. See "[RS232 Communication buffer indicator bar](#)," page 6–2.
- (8) Current time. The time is updated every second. If you are using a network connection, the monitor id is displayed (from the network plug connected to the monitor, if available).
- (9) Use the graph palette to scroll the display area of the graph and to zoom in and out of sections of the graph. The graph palette is available only when graphs are frozen. See "[Appendix A: Graph palette](#)" for details.

Command buttons



Freeze stops updating the waveform and trend graphs.

DCR saves all alarm, trend and waveform data shown to a Datex Record Interface format file (.drc) starting from the moment you press this button. For details, see "[Saving data in .drc files](#)" on page 4-13.

ASCII saves alarm, trend and waveform data to separate ASCII files. The button is available only if DRC saving has been activated. For details, see "[Saving data in ASCII files](#)" on page 4-14.

Stop stops the current recording to a file.

Resizing the main window

You can resize the main window by selecting **Window - Resize** (Ctrl+S). This may be useful when you use, for example, Office applications on the same PC while collecting data.

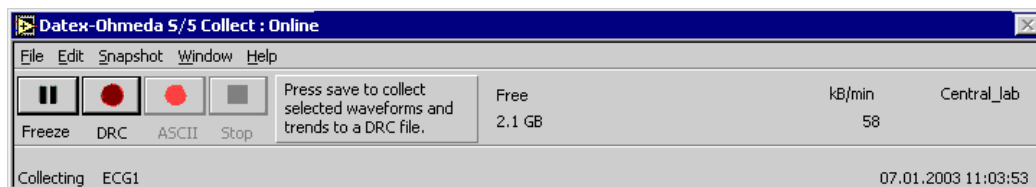

Figure 4-3 Resized main window

Online waveforms

In the main window, select the Waves page.

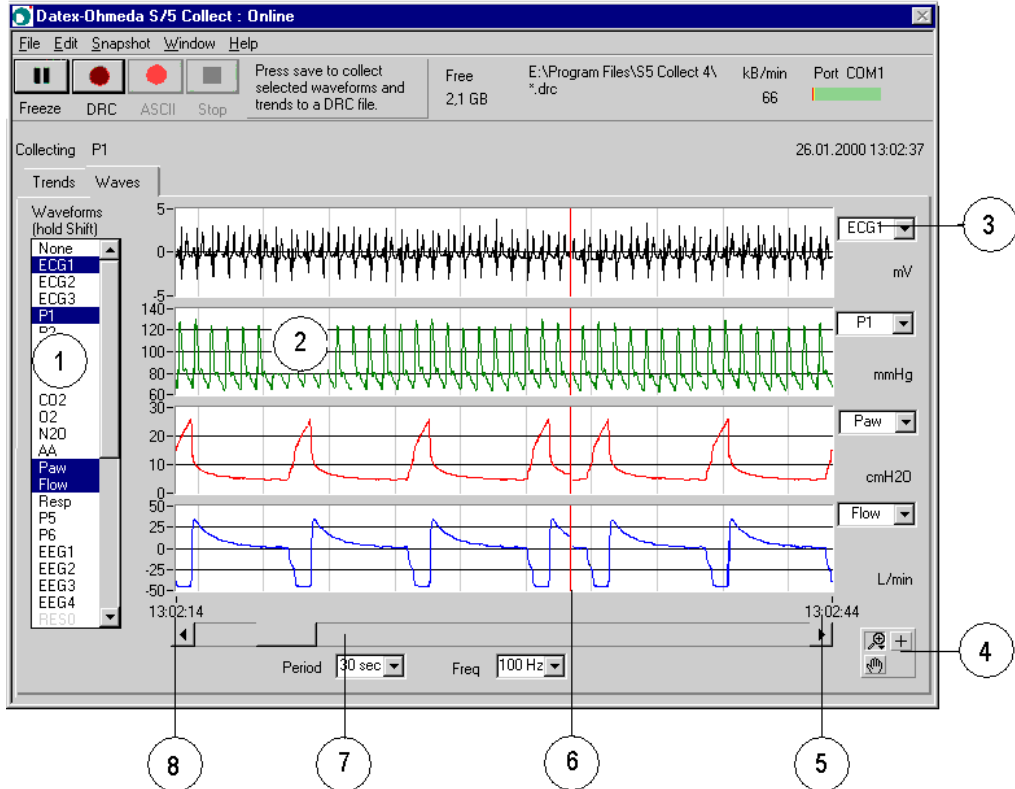

Figure 4-4 Online Waves page

- (1) Waveforms available for selection
- (2) A maximum of 4 waveform boxes
- (3) The waveform selected to be displayed in the first waveform box. The unit used is displayed under the selection box.
- (4) Use the graph palette to scroll the display area of the graph and to zoom in and out of sections of the graph. The graph palette is available only when graphs are frozen. See "[Appendix A: Graph palette](#)" for details.
- (5) Waveform end time
- (6) Red waveform cursor. The waveform at the waveform cursor is 3 seconds delayed from the actual waveform shown on the monitor screen.
- (7) Scroll bar and scroll box. By moving the scroll box you can move to the desired part of the waveform.
- (8) Waveform start time

Selecting the displayed waveforms

The waveform selection list on the left (**Waveforms**) defines the waveforms that are available for viewing in the boxes. The list contains all the waves the maximum monitor configuration can measure.

- To select only one wave, click the wave in the list, and to select more waves, hold down Shift and click the desired waves.
- To deselect waves in the list, hold down Shift and click the wave.
- After selecting the wave(s), click the arrow button next to the waveform selection box and select the wave you wish to see in the waveform box.



NOTE: When using the 12-lead ECG module, only ECG1, ECG2 and ECG3 are available.

Changing the waveform sampling interval

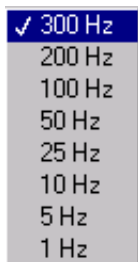

Click **Freq** and select the frequency. The sampling frequency in the online mode can be selected from 300 to 1 Hz.

During network communication the maximum number of waves that can be requested is 24.

During serial communication, the maximum frequency available depends on which waveforms are being collected. For example, ECG has 300 Hz, hemodynamic waveforms 100 Hz and gas and spirometry waveforms 25 Hz.

If too many waves are selected, a prompt to reduce the amount of waveforms is displayed. The limit is a total of 600 samples per second; for example

2 * 300 Hz or

1 * 300 Hz + 3 * 100 Hz or

6 * 100 Hz or

2 * 100 Hz + 6 * 25 Hz or

8 * 25 Hz.

If you are collecting data from a longer period of time to an ASCII file, select a low frequency to reduce the file size.

NOTE: With certain monitor software versions, there may be a risk that the waveform transfer is interrupted after selecting the 1 sec as the trend sampling interval. In such case, you will also be prompted to select less waveforms.

Data file size

The table on page B-6 in "Appendix B" shows the frequency for each wave. The value must be multiplied by 2 to get the number of bytes/second. The overhead each second is 40 bytes. Trend data takes about 1500 bytes per request.

An example of asking parameters each hour for a total period of 2 days (all trend parameters are saved in the .drc file regardless of your selection):

$(2 \times 24) \times 1500 = 72 \text{ kB}$.

An example of collecting 2 waveforms per hour and trend data each 5 seconds:

3600 seconds 2 x InvBP waves + trend each 5 seconds =
 3600 x 2 x (100 x 2 + 40) + 3600/5 x 1500 =
 864 kB + 144 kB = 1008 kB

It is not possible to predict the exact file size of the ASCII files. The number of characters in the values may make a big difference in the file size, for example, if the invasive pressure is 3.00 mmHg or 120.00 mmHg there are 4 or 6 characters written in the file.

The online data collecting shows the file sizes while saving the data and the data rate in kB/min. From these values, you can estimate the hard disk occupation and when the saving can be made.

NOTE: The frequency selection does not affect the data transfer rate, which is always the maximum. The data is stored in .drc files for each wave at its individual rate. The data is displayed and saved in ASCII files at the chosen frequency.

Changing the period of waveform display

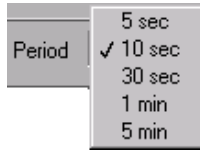

Click **Period** and select **5 sec, 10 sec, 30 sec, 1 min., 5 min.**

When you change the period of the waveform display, the start and end times on the scroll bar at the bottom of the page change accordingly. By moving the scroll box you can move to the desired part of the waveform.

The recommended value depends on the selected waveform. For example, if you select 1 minute for ECG waveforms, the artifacts cannot be read from the displayed waveforms. When you change the period, for example, to 10 seconds, the waveform becomes much clearer.

Online trends

In the main window, select the Trends page.

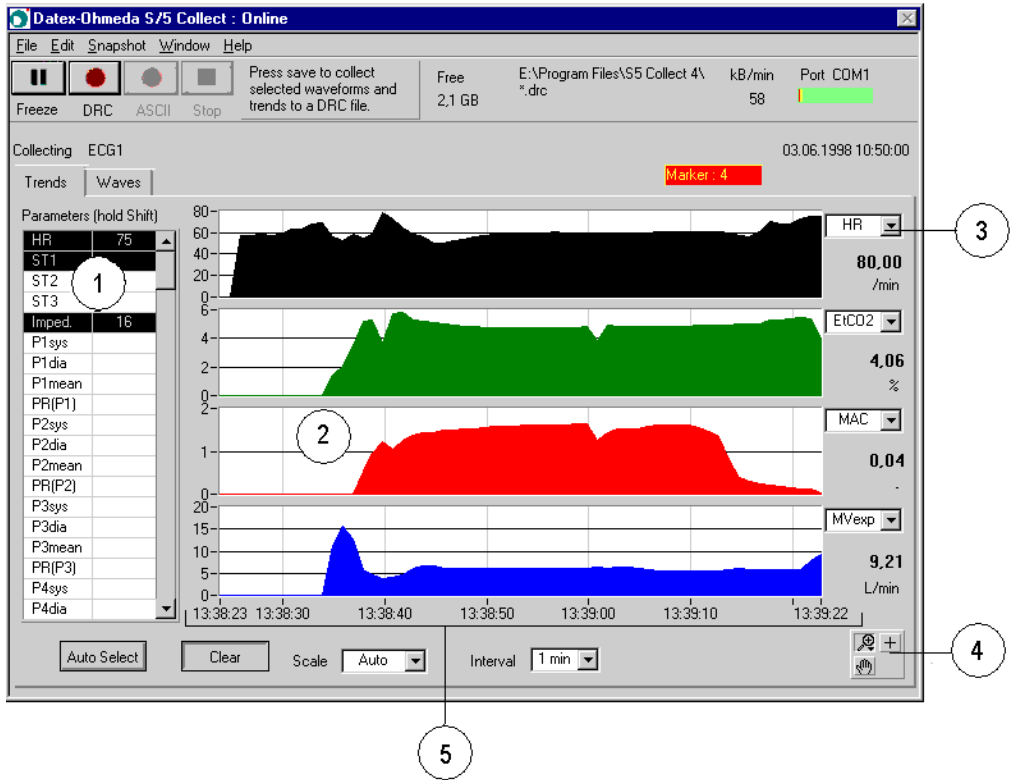

Figure 4-5 Trends page in online mode

- (1) Trends available for selection
- (2) A maximum of 4 trend boxes
- (3) The trend selected to be displayed in the first trend box. The latest numerical parameter value and the unit are also displayed.
- (4) Use the graph palette to scroll the display area of the graph and to zoom in and out of sections of the graph. The graph palette is available only when graphs are frozen. See "[Appendix A: Graph palette](#)" for details.
- (5) Trend times

The online trend data is real-time. If the PC is very slow and a lot of waves are being asked, trend data may also be buffered. This is indicated in the communication buffer indicator in the upper right corner.

Selecting the displayed trends

The **Parameters** selection list defines the parameters that are available for viewing. The list contains all parameters that the maximum monitor configuration can measure.

- To select only one parameter, click it.
- To select more parameters, hold down Shift and click the parameters.
- To deselect parameters in the selection list, hold down Shift and click a parameter that you wish to deselect.
- After selecting the parameters from the list, click the arrow button next to the trend box and select the parameter you wish to see in the trend box.



Auto-selection of displayed trends

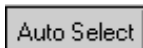

Clicking **Auto Select** will select and display all data with a positive value greater than 1 times the resolution as defined by the divider for the parameters in the configuration window.

Checking the latest numerical parameter value



The latest read numerical parameter value is shown to the right of the trend box under the trend selection box in a digit field. The latest read values are also displayed next to the parameters in the **Parameters** list.

Changing the trend sampling interval



Click **Interval** and select **1 sec, 5 sec, 10 sec, 30 sec, 1 min, 5 min, 10 min, 30 min** or **1 hour**.

NOTE: **1 sec** and **5 sec** are not available during network connection.

When you want to see quick changes in the trends, select a short interval, for example, 5 seconds. When you want to see the overall direction of the trends, select a longer interval, for example, 1 minute. If you are collecting data from a long period of time, for example several hours, and have selected a short interval, the `.drc` file becomes quite large.

NOTE: With certain monitor software versions, there may be a risk that after selecting the 1 sec trend interval, the waveform transfer is interrupted. In such case, you will be prompted to select less waveforms.

Changing the trend scale

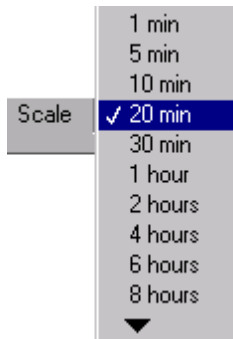

Click **Scale** and select the desired trend time scale from values **1 min, 5 min, 10 min, 20 min, 30 min, 1 hour, 2 hours, 4 hours, 6 hours, 8 hours, 12 hours, 24 hours** and **Auto**. The trend boxes start showing trends using the selected scale. The start and end times under the trend panel change accordingly.

If you select **Auto**, the time scale is autoscaling all the time: the start time is the start of the collection period, or the moment the graph was cleared last, and the end time is the time of the last package received.

Clearing the trends



Clicking the **Clear** button clears the displayed graphs and deletes the history of each graph.

Freezing the online trends and waveforms



If you want to stop updating both the trends and the waveforms simultaneously, press the **Freeze** button. Press it again to continue updating the display.

Displaying alarms

Select **File - Alarms** (Ctrl+A) to display all parameter alarms from the monitor. By default, the alarms are not displayed.

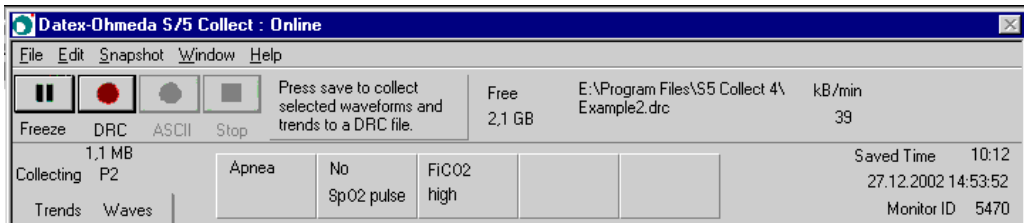

Figure 4-6 Alarms displayed in the online mode

NOTE: If this selection is off, the alarms are not saved in .drc and ASCII files.

Displaying events

Select **File -Events** (available only with network communication) to display all events from the monitor.

Events include, for example, changes in demographic data, values entered in the calculation view, setting changes of interfaced devices, or changes in record keeping menus. By default, the events are not displayed.

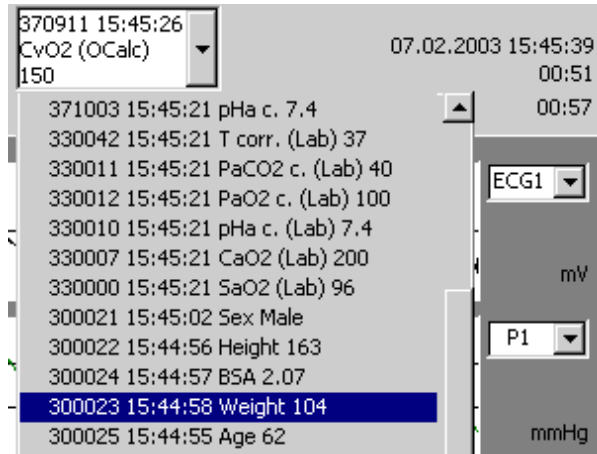

Figure 4-7 Events displayed in the online mode.

The event is preceded by an event code and its time of occurrence. The last 100 events are shown in the list.

All events will be automatically added to the notes belonging to the saved `.drc` file after the online window has been closed.

Saving data in `.drc` files



- To start recording data in a `.drc` file, click the **DRC** button. All trend parameters will be saved regardless of the selection. Only the selected waveforms will be saved (at a maximum frequency).
- To include alarm data in the `.drc` file, remember to first display the alarms by selecting **File - Alarms** (Ctrl+A). By default the alarms are not displayed nor saved.

- To include event data in the .drc file, remember to first display the events by selecting **File -Events** (only available with network communication).By default the events are not displayed nor saved.
- When you have clicked the **DRC** button, the application starts saving the data. You will be prompted for the filename. You can see the amount of saved data under the **DRC** button.
- Click the **Stop** button when you have saved the desired amount of data.

Saving data in ASCII files



NOTE: This function is not available for unregistered users.

NOTE: The ASCII button is available only, if DRC saving has been started.

- To start saving data in ASCII files, click **ASCII**. Only the selected trends and waveforms will be saved.
- To save alarm data in an ASCII file, remember to have the **File - Alarms** (Ctrl+A) selection on. By default this is off.
- You will be prompted for the name of the trends file, waves file and alarms file separately. By default, file names `trends.asc`, `waves.asc` and `alarms.asc` are used. The waveforms will be saved at the chosen frequency.
- You can see the total size of all saved ASCII files under the **ASCII** button.
- When you have saved a desired amount of data, click the **ASCII** button again. The output file formats are shown in "[Appendix B: File formats](#)".

NOTE: The decimal symbol saved in the ASCII file follows the Windows settings (**Start - Settings - Control Panel - Regional Settings**). Programs like Microsoft Excel also follow this setting. When transferring the ASCII files between different computers, make sure that the decimal symbol has been set the same on all computers.

NOTE: If you click **Stop**, both DRC saving and ASCII saving are stopped.

Entering and modifying notes

You can enter and modify case notes by selecting **Edit - Notes** (Ctrl+N) in the main window. You can select notes from a predefined list, or enter notes of your own. Here you can, for example, enter drug administrations and their effects on the patient. The information entered in notes is first saved in a temporary .txt file and copied to a .txt with the same root as the .drc file when the saving is completed. The notes can be viewed and re-edited in the offline mode.

The notes are not copied when saving only to an ASCII file.

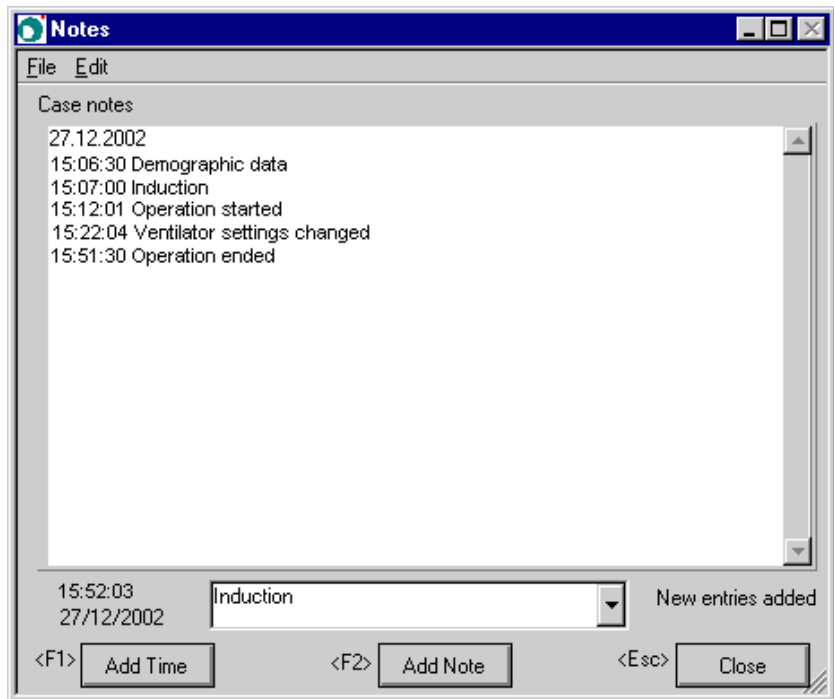

Figure 4-8 Notes dialog box

- To select a predefined note from the list at the bottom and add it in your notes, click the list of predefined notes, select the desired note and then select **Edit - Add Note** (F2) or click **Add Note**. The note is added in the list of notes together with a timestamp.
- In the Notes window, to enter a note that is not predefined, first insert a timestamp by selecting **Edit - Add Time** (F1) or clicking **Add Time**. If you also wish to add a date, select **Edit - Add Date + Time**. After this, enter the note manually.

- You can generate a marker automatically by pressing the **Take Snapshot** button on the patient monitor. At the next reading of the parameter data to the notes, a line is automatically added in the **Case notes** with the time and the marker number.
- You can remove the contents of the **Case notes** by selecting **File - New**.
- The predefined notes are stored in `notes.lst`, which can be edited using a text editor. You can add the current case notes in the selection list by selecting **File - Store Notes - Add Case Notes to Selection List**. You can replace the contents of the selection list with the current case notes by selecting **File - Store Notes - Replace Selection List with Case Notes**. All data and time stamps will be automatically removed before the line is made a predefined note.
- To print the **Case notes** shown in the Notes window, select **File - Print** (Ctrl+P).
- You can open a saved `notes.txt` file by selecting **File - Open** (Ctrl+O).
- You can export the note entries directly to an Excel worksheet by selecting **File - Export to Excel** (Ctrl+E).

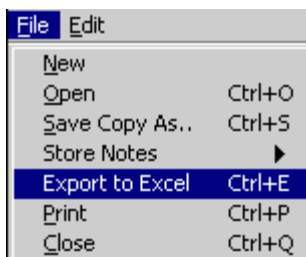

Figure 4-9 File menu

Taking snapshots

A snapshot contains all data in the memory (max. 30000 samples). A maximum of four parameters or waveforms can be displayed at a time. The snapshots are shown for the parameters that have been selected to be displayed in the main window.

To display snapshots in the online mode, select **Snapshot - Trend** (Ctrl+T) or **Wave** (Ctrl+W).

Graphical presentation of trend and waveform snapshot data

All page - snapshots off all selected waveforms or trends

Select **Snapshot - Trends** (Ctrl+T) or **Wave** (Ctrl+W) and **All** to show snapshots for all four parameters or waveforms selected to be displayed in the main window. The X axis shows the time and the Y axis the parameter values.

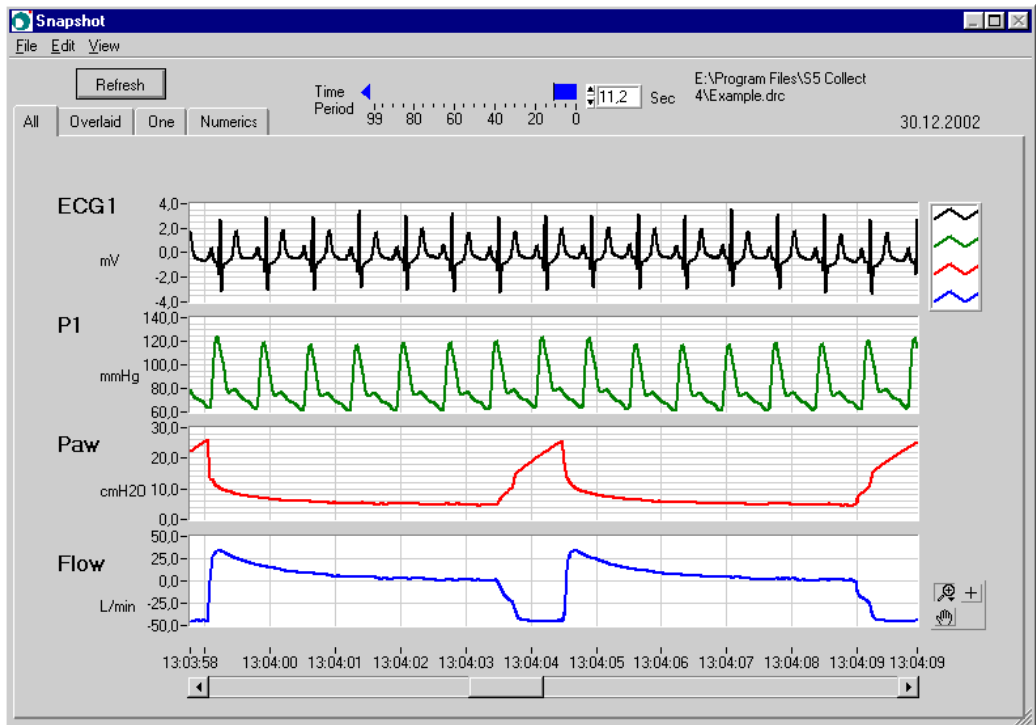

Figure 4-10 Waveform snapshots - All snapshots page in online mode

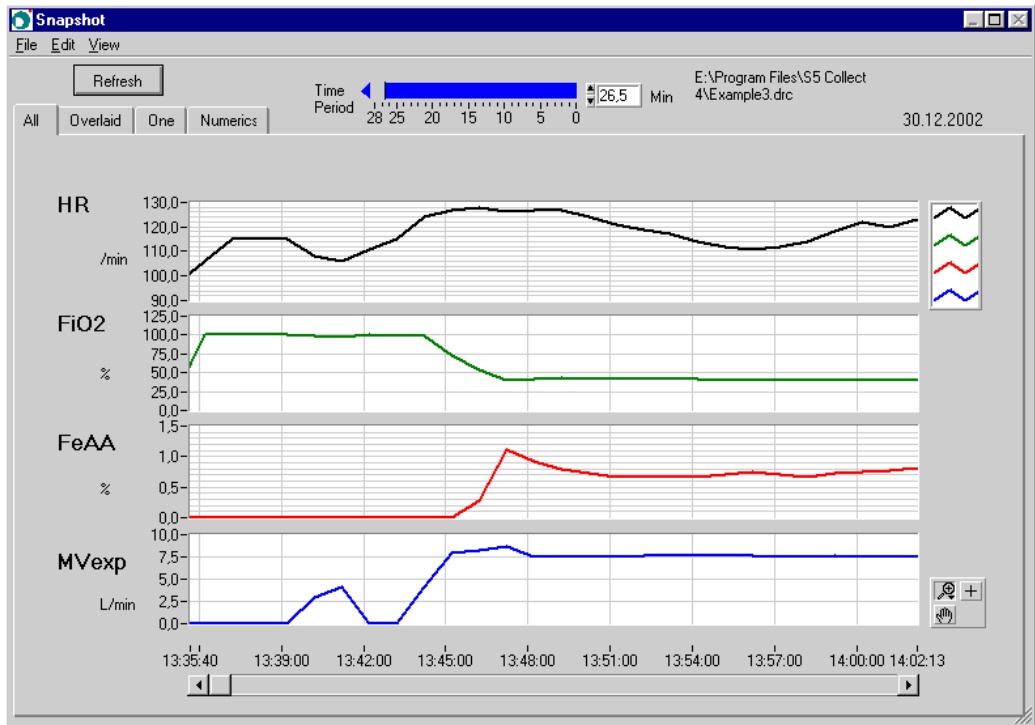

Figure 4-11 Trend snapshots - All snapshots page in online mode

Overlaid page - overlaid snapshots of waveforms or trends

Select **Snapshot - Trend** (Ctrl+T) or **Wave** (Ctrl+W) and **Overlaid** to display a snapshot for 4 overlaid trends or waveforms at a time. You can select and deselect each parameter from the checkboxes on the left. The X axis shows the time and the Y axis the parameter values.

The Overlaid page is useful, for example, when you are comparing two trends or waveforms.

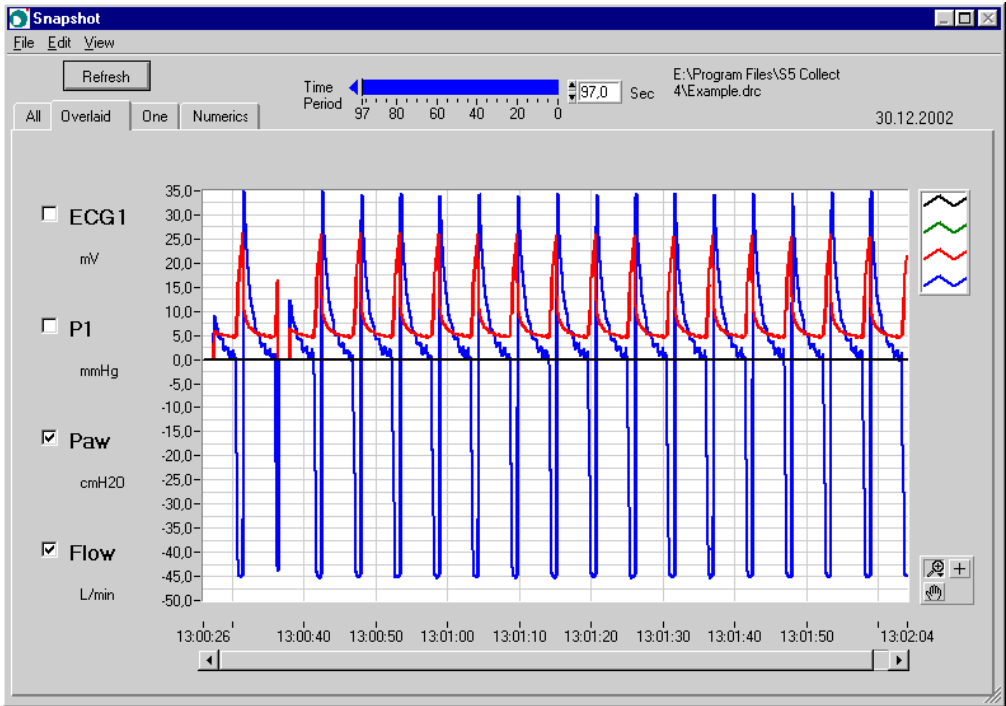

Figure 4-12 Waveform snapshots - Overlaid snapshots page in online mode

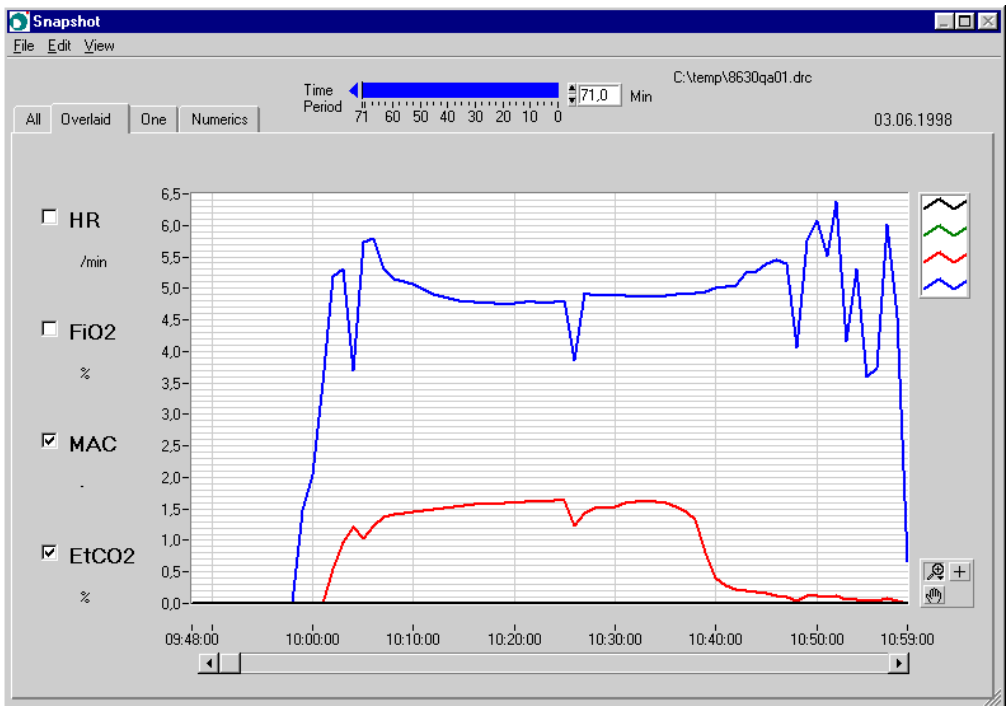

Figure 4-13 Trend snapshots - Overlaid snapshots page in online mode

One page - a snapshot of one waveform or trend

Select **Snapshot - Trend** (Ctrl+T) or **Wave** (Ctrl+W) and **One** to show a snapshot for one trend or waveform at a time. You can select the parameter from the parameter list. The X axis shows the time and the Y axis shows the parameter values.

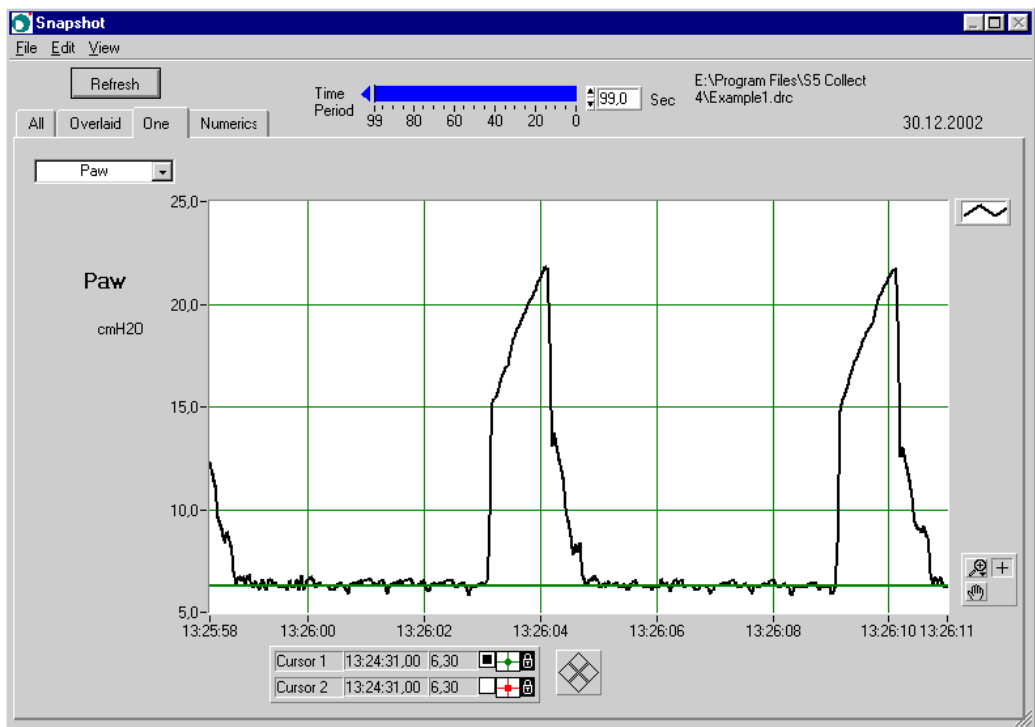
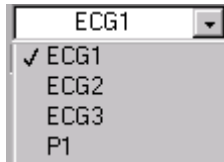

Figure 4-14 Waveform snapshots - One snapshot page in online mode

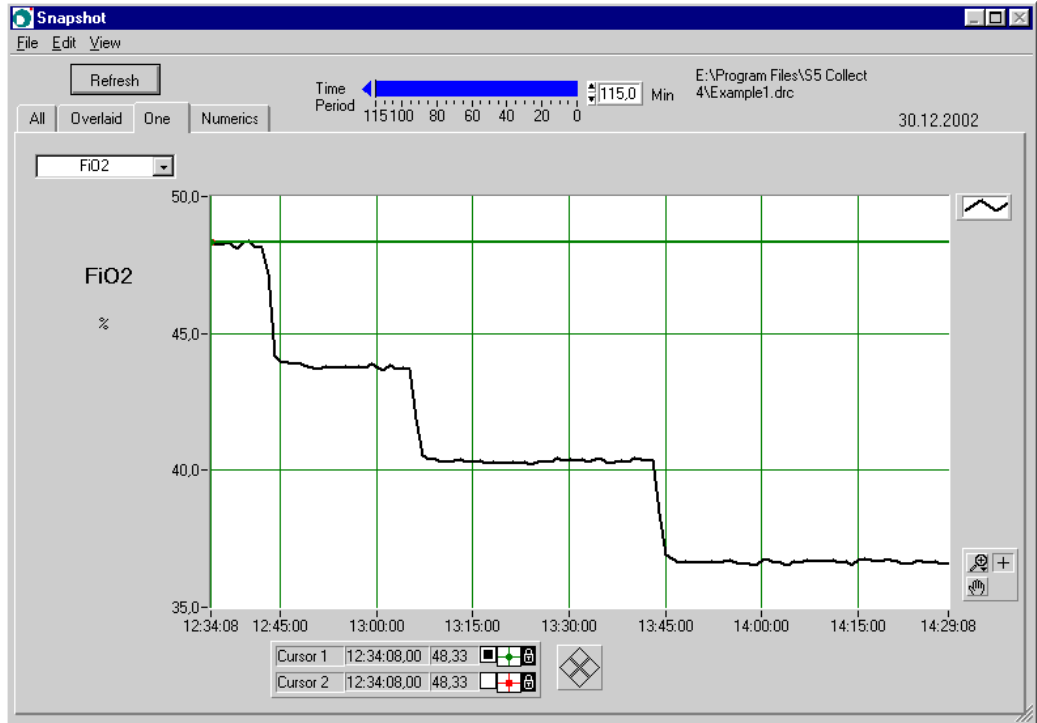



Figure 4-15 Trend snapshots - One snapshot page in online mode

Working with graphical snapshots

- The **Time period** bar defines the total time period. To rescale the snapshot in time, click the bar above the number of seconds or minutes needed. For example, if you wish to display trend for a period of 33 seconds, click the bar above 33.
- To have a closer look at a snapshot, use the  to zoom the desired part. By clicking the left end of the **Time period** bar at the top of the snapshot screen you get the total period again.
- You can refresh the snapshot with the latest collected data using the **Refresh** button at the top.
- The slide bar at the bottom defines which part of the data is visible. To show another time point, slide the slide box to the desired start point.
- To display the pop-up menu for the graphical snapshot window, click the right mouse button.
- To autoscale the X axis or Y axis, click the graph area with the right mouse button and select **AutoScale X** or **AutoScale Y** to autoscale the X axis or Y axis respectively.

- You can clear the chart by selecting **Clear Chart** from the pop-up menu.
- To display or hide the X scale and Y scale for all of the graphs simultaneously, select **Visible Items - X Scale** or **Y scale** from the pop-up menu.
- To display a numeric data box under each the graph, select **Visible Items - Digital Display** from the pop-up menu. The value is the last value in the right part of the graph.
- To display or hide the scrollbar, select **Visible Items - Scrollbar** from the pop-up menu.
- There are several palettes available for working with the graphs. To show them, select **Visible Items** from the pop-up menu and select the desired palette. For details about these palettes, see "[Appendix A: Using LabVIEW palettes.](#)"
- To print the currently shown snapshot page on paper on your default printer, select **File - Print** (Ctrl+P).
- To hide the **Time period** bar and tab page names, select **View - Graph Only**.
- To save the snapshot page in a picture file, select **File - Save Graph As** and select **.bmp** (Ctrl+B), **.png** (Ctrl+J) or **.jpeg** (Ctrl+G). The picture file contains same data as the paper printout. The **.bmp** files are big in size, **.jpeg** files are smaller, but may cause loss of some pixel information. The **.png** files are the smallest containing all text and lines. They can be read by most Microsoft Office applications.

Numeric presentation of trend and waveform snapshot data

Select **Snapshot - Trend** (Ctrl+T) or **Wave** (Ctrl+W) and **Numerics** to show a numeric presentation of the data shown currently in all four trends or waveforms in the selected time period.

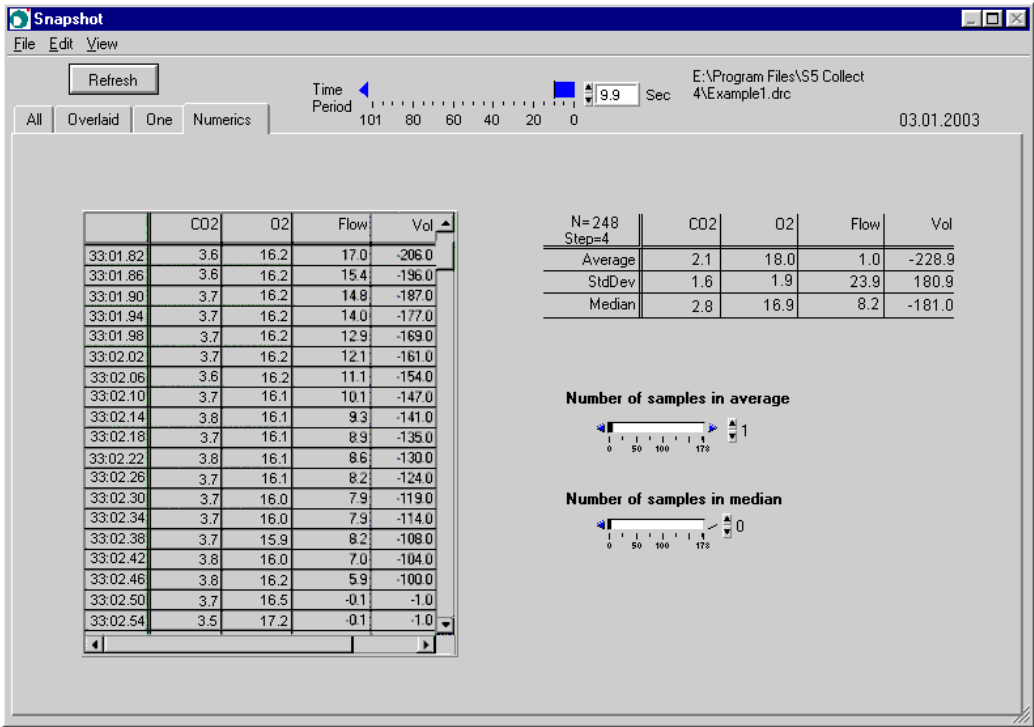

Figure 4-16 Waveform snapshots - Numerics page in online mode

- The **Time period** bar defines the total time period. To rescale the snapshot in time, click the bar above the number of seconds or minutes needed. For example, if you wish to display trend for a period of 33 seconds, click the bar above 33.
- Click **Refresh** to update with the latest data collected.
- The table contains the total time period defined by the **Time period** bar and the four parameters or waveforms selected in the main window together with their values.
- The values next to the table are average, standard deviation and median values of the displayed parameters.

- The **Number of samples in average** and **Number of samples in median** field can be used to filter the data in the table and all graphs in the snapshot. Increasing **Number of samples in average** will apply a sliding window average, where the **Number of samples in average** is the same as the number of samples in the window. This filter smoothens the effect of the artifacts. Increasing **Number of samples in median** will sort each window by **Number of samples in median**, and pick up the middle value of the sorted data. This filter can be used to completely rule out artifacts in the data.
- To show the currently selected table cells, click the right mouse button and select **Show Selection** from the pop-up menu.
- To hide the **Time period** bar, select **View - Graph Only**.
- To print the currently shown snapshot page on paper, select **File - Print** (Ctrl+P).
- To save the snapshot page in a picture file, select **File - Save Graph As** and select **.bmp** (Ctrl+B), **.png** (Ctrl+J) or **.jpeg** (Ctrl+G). The picture file contains same data as the paper printout. The **.bmp** files are big in size, **.jpeg** files are smaller, but may cause loss of some pixel information. The **.png** files are the smallest containing all text and lines. They can be read by most Microsoft Office applications.

Exporting snapshot data to ASCII and Excel

You can save the data in the displayed snapshot to an ASCII file by selecting **File - Export Table - To ASCII** (Ctrl+S).

You can save the data in the displayed snapshot to an Excel worksheet by selecting **File - Export Table - To Excel** (Ctrl+E). This may take a while.

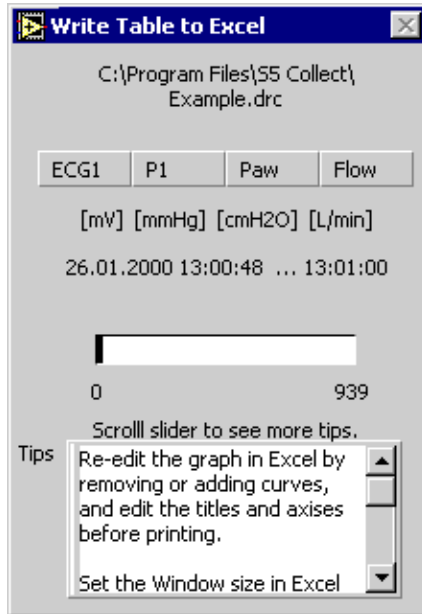
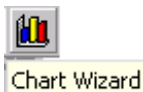

Figure 4-17 Status window displayed during data transfer to Excel

Tips for using the data in Excel

- Re-edit the graph in Excel by removing or adding curves, and edit the titles and axes before printing.
- Set the Window size in Excel to **Selection** to view the complete graph. You can do this by selecting **View - Zoom - Fit selection**.
- If the **Time** column includes a **Date**, Excel may not interpret the fields correctly. In such a case, select the column and use **Edit - Replace** and replace ":" with ":".
- When placing a curve on the right axis, remember to edit the order of unit texts on the Y-axis.

- Select graph in Excel and click the **Chart Wizard** icon to select, for example, a chart type with markers or smoothing data.



- After reformatting a graph once, you can save the graph format and use the same format again for the next graph. To do this, select **Chart - Graph Type** in Excel. Go to the **Custom Types** page and select the **User-defined** option button. Then click the **Add** button and give a name and a description to your chart. You can set your chart to be used as the default chart by clicking the **Set as default chart** button.

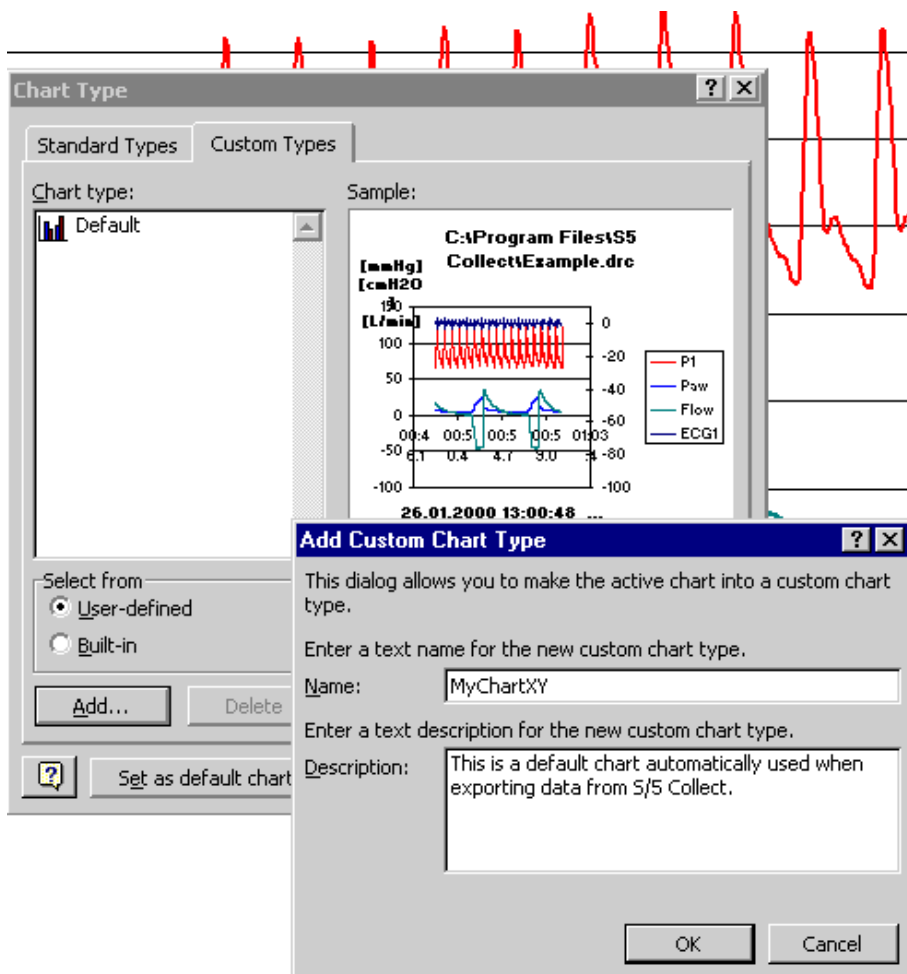

Figure 4-18 Making a user-defined chart to be used as a default chart type

Using plug-ins

A plug-in is a virtual LabVIEW instrument that can be modified using LabVIEW 6.1. Plug-ins can be used for customizing the format of showing the collected data on the screen, or for performing additional calculations with the data online or offline.

A plug-in can run on any PC when called by the S/5 Collect without having the LabVIEW editor itself installed on the PC. The S/5 Collect uses the NI LabVIEW RunTime Engine 6.1 to run the plug-ins.

NOTE: The S/5 Collect needs to be registered to be able to run plug-ins.

In the main window, select **Window - Select Plugin**. A list of available plug-ins is displayed.

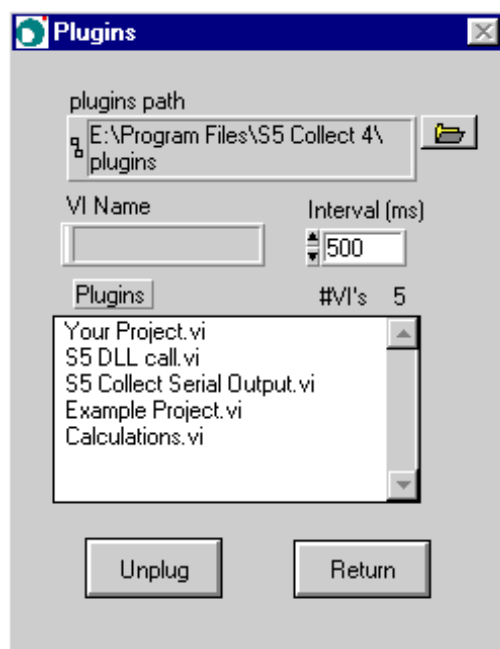

Figure 4-19 Plug-in window

The plug-in files should be located in the directory indicated in the **Plugins path**.

If the program has been installed to `C:\Program Files\S5 Collect 4`, the default directory at first startup is `C:\Program Files\S5 Collect 4\plugins`. You can change the plug-in path using the browse button.

One plug-in (`S5_DLL_Call.vi`) calls a number of functions in a `.dll` file (Dynamic Link Library). The sources of these functions are also located in the default plug-ins directory, and may be recompiled using, for example, Visual C to include special functions or algorithms. The results can be stored to an additional output file for later review.

When the plug-in has been selected, the virtual LabVIEW instrument will be opened and called at regular intervals passing new data to the plug-in.

The calling interval can be changed in the online mode, see [Figure 4-17](#) above.

The plug-in window may be reopened by selecting **Window - "Plugin Name"**.

See "[Appendix C: Plug-ins](#)" for information how to program plug-ins.

Printing the current window

You can print a paper copy of the current S/5 Collect window on your default printer by selecting **File - Print** (Ctrl+P).

Exiting the online mode

In the main window, select **File - Exit** (Ctrl+Q) or press Esc. The S/5 Collect startup window is displayed. Now you can exit the program, start serial communication or go to offline mode.

5 Using the S/5 Collect offline

Starting the offline mode

To be able to use the S/5 Collect offline, you need to have `.drc` files saved in your system.

NOTE: If you do not have any `.drc` files yet, and want to see how they look like, you can open one of the example `.drc` files, which the installation program has installed in the S/5 Collect program directory. The example `.drc` files can also be found on the product CD-ROM in the directory `\Patient Data`.

1. Click **Offline** in the startup window. A window for selecting the `.drc` file is displayed.

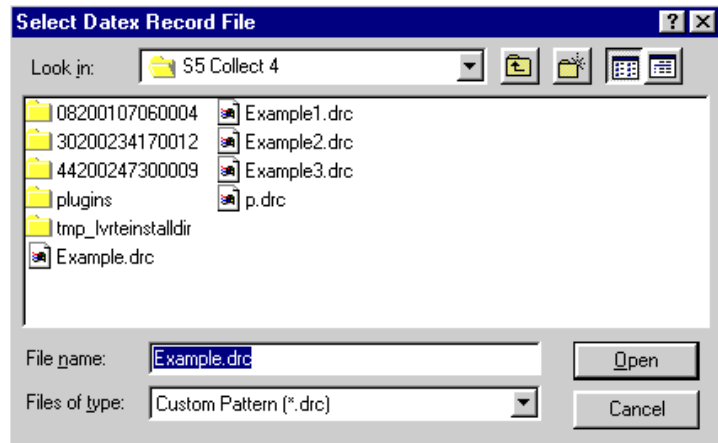

2. Select the desired `.drc` file and click **Open**.

The program starts replaying the first data record. After a few trend data points the following prompt is displayed:

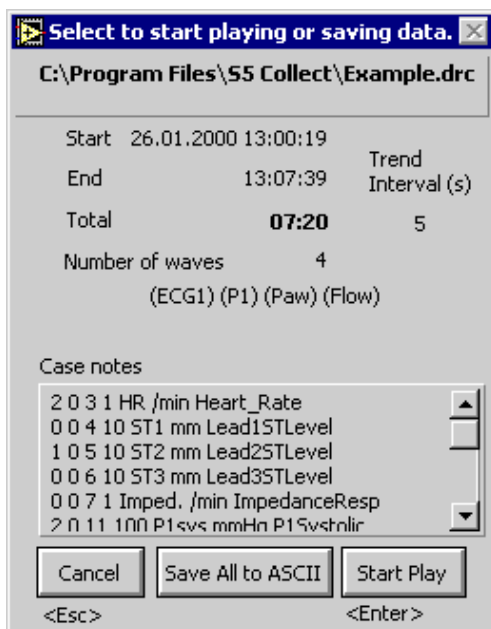



Figure 5-1 Select to start playing or saving data

- To save all data in the .drc into an ASCII file without replaying the file on the screen, select **Save All to ASCII**.
Trends will be saved with the trend interval that was set while saving to a .drc file in online mode.
Waves will be saved at the previously selected frequency.
- To start replaying the data, select **Start Play**.
To stop the replaying, click  or press F3.
- To cancel and return to the startup window, select **Cancel**.

Offline main window



Figure 5-2 Example of the main window in offline mode

- (1) Command buttons for replaying data, saving, taking snapshots and opening new files.
- (2) Four tab pages: **Trends**, **Waves**, **Trends XY** and **Waves XY**.
- (3) Name of the opened .drc file.
- (4) The amount of data to read
- (5) Date and time on the monitor screen, relative time, total time in the file. (See "Times displayed in the offline mode" below for details.)
- (6) Use the graph palette to scroll the display area of the graph and to zoom in and out of sections of the graph. The graph palette is available only when data reading has stopped. See "Appendix A: Graph palette" for details.

Times displayed in the offline mode

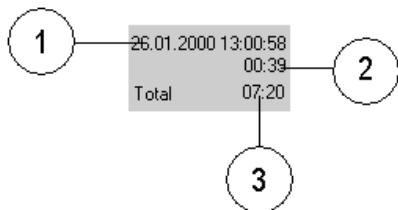

- (1) Date and time on the monitor screen.
- (2) The time relative to the start of the file being read.
- (3) The total amount of time in the file

Figure 5-3 Times displayed in the offline mode

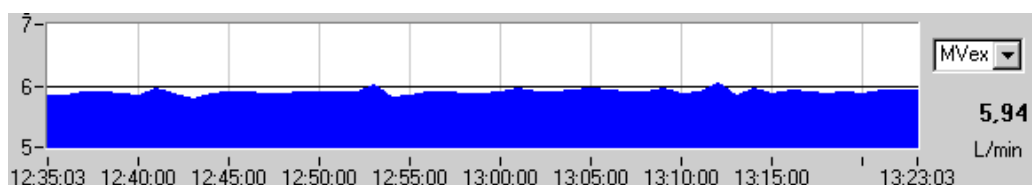

Figure 5-4 Example of the time bar at the bottom of the Trends page

On the Trends page, the rightmost time is the time of the last data package read. The leftmost time depends on the **Scale** setting. If the **Scale** is, for example, **10 min**, and the time of the last data package is 13:07:36, the leftmost time is 12:57:36.

If the **Scale** setting is **Auto**, the leftmost time is the time of the first package in the memory, or if you clicked **Clear**, the time of the first package after clicking **Clear**.

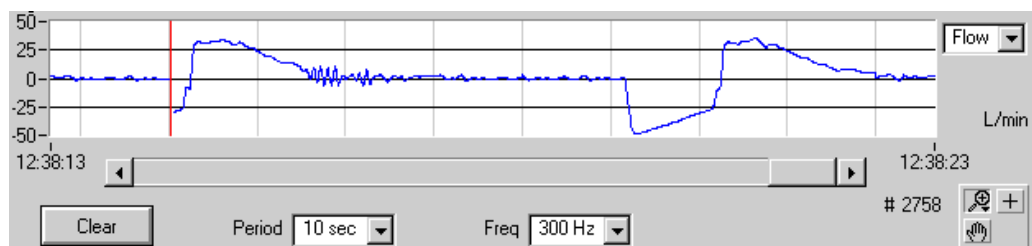

Figure 5-5 Example of the time bar at the bottom of the Waves page

On the Waves page, the rightmost time under the waveform boxes is the leftmost time plus the **Period** setting. The red waveform cursor shows the moment of the last package received.

Replaying the data in offline mode

The following command buttons that are needed for replaying the data saved in the `.drc` files are available on all offline mode main window pages.



Click **Clear** to clear the display memory.

This button is useful, for example, if you change the parameters displayed in the trend boxes or waveform boxes, and wish to show the data from that point onwards.

The program automatically selects **Clear**, if you change display settings, and the button color turns to red. This clears the display memory. The trend and waveform boxes show the data from the point you clicked **Clear**.



or F2

Start reading from the beginning of the file.



or F3

Stop the current action at any moment.



or F4

Jump to a desired time in the file. You can also use **Edit - Go to Time**.



or F5

Start replaying the data slowly from the `.drc` file. This shows trend, alarm and waveform data.



or F6

Play the data fast.



or F7

Start winding forward without showing any trends or waveforms. Each record will be read. You can check the time and the percentage read indicators for progress and click the **Stop** button (F3) at the time you are looking for.



or F9

Set an automatic stop for any action. You can also use **Edit - Auto Stop**.



or F1

Open another `.drc` file.



or F10

Take a snapshot of the Waves page or Trends page.

Offline waveforms

In the main window, select the Waves page.

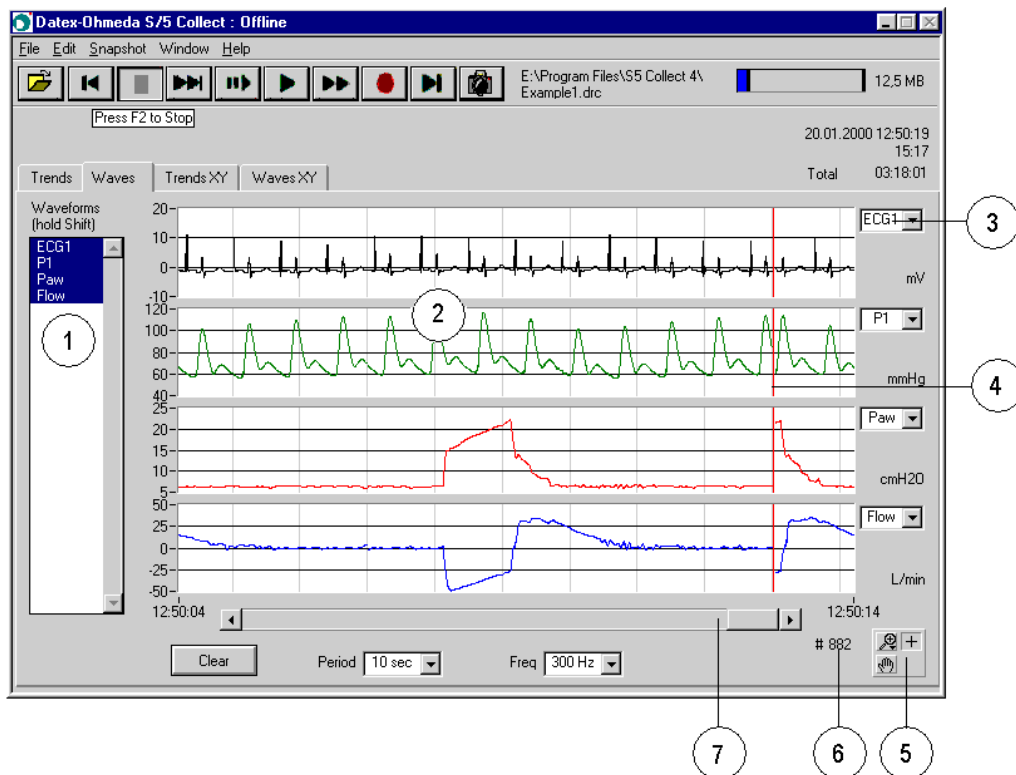

Figure 5-6 Waves page - offline mode

- (1) The **Waveforms** selection list defines the waveforms that are available for displaying in the waveform boxes.
- (2) A maximum of 4 boxes for waveforms. The X axis indicates the time and the Y axis indicates the values.
- (3) You can change the waveform displayed in a particular box from the waveform selection box.
- (4) The red waveform cursor shows the moment of the last package read.
- (5) Use the graph palette to scroll the display area of the graph and to zoom in and out of sections of the graph. The graph palette is available only when data reading has stopped. See "[Appendix A: Graph palette](#)" for details.
- (6) The number indicates the number of waveform records read from the file.
- (7) You can move to the desired part of the waveform by moving the scroll box.

Selecting the displayed waveforms

- To select only one waveform, click the item in the list. To select more waves, hold down Shift and click the desired waveforms.
- To deselect waveforms in the selection list, hold down Shift and click the waveforms that you wish to deselect.
- After selecting the wave(s), click the arrow button next to the waveform selection box and select the wave you wish to see in the waveform box.

Changing the waveform sampling interval

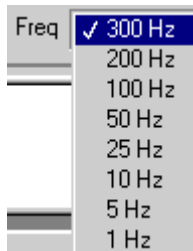

Click **Freq** and select the frequency. The sampling frequency in the offline mode can be selected from 300 to 1 Hz. This effects the frequency shown in the offline window and the frequency of samples stored to ASCII files.

Changing the period of waveform display

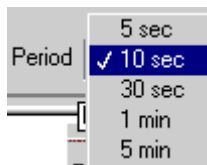

Click **Period** and select **5 sec**, **10 sec**, **30 sec**, **1 min.**, **5 min.**

When you change the period of the waveform display, the start time and the end time values change accordingly on the scroll bar at the bottom. By moving the scroll box you can move to the desired part of the waveform.

The recommended period value depends on the selected waveform. For example, if you select 1 minute for ECG waveforms, the artifacts cannot be read from the displayed waveforms. When you change the period, for example, to 10 seconds, the waveform becomes much clearer.

Clearing the waveforms



Click **Clear** to clear the displayed graphs and the display memory.

Offline trends

In the offline main window, select the Trends page.

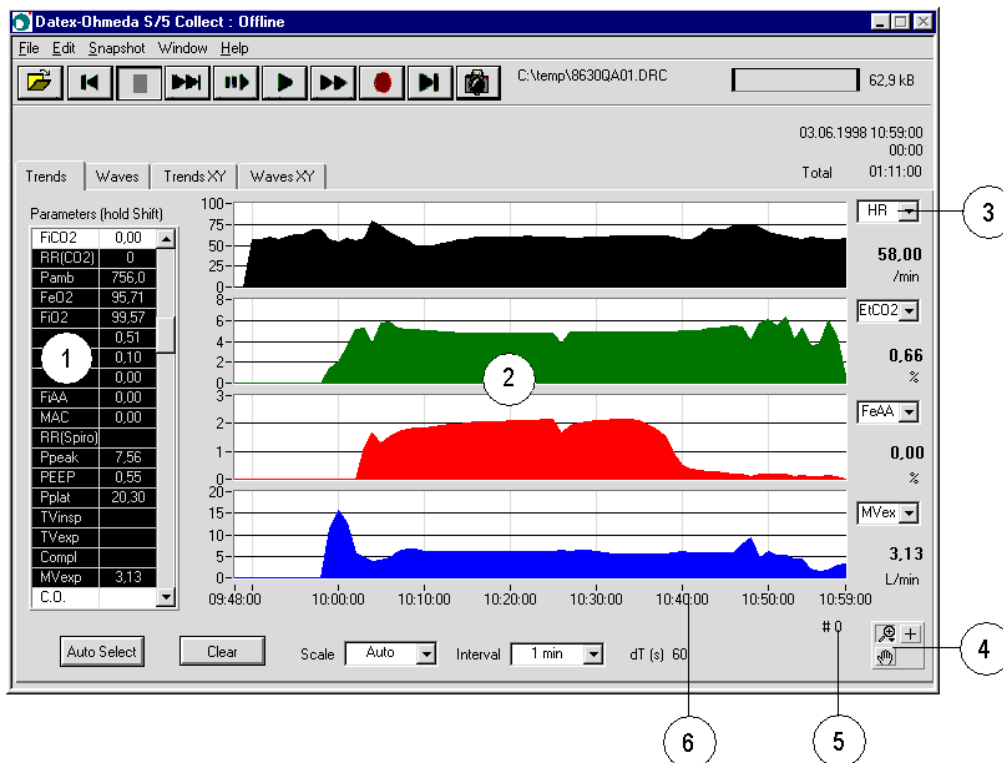
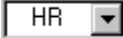

Figure 5-7 Trends page - offline mode

- (1) The **Parameters** selection list on the left defines the trends that are available for displaying in the trend boxes.
- (2) The window contains 4 boxes for trends. The X axis indicates the time and the Y axis indicates the values.
- (3) You can change the parameter displayed in a trend box from the parameter selection box. The latest numerical parameter value and the unit are also displayed.
- (4) Use the graph palette to scroll the display area of the graph and to zoom in and out of sections of the graph. The graph palette is available only when data reading has stopped. See "[Appendix A: Graph palette](#)" for details.
- (5) This number indicates the number of trend records read from the file
- (6) Trend times

Selecting the displayed trends

1. To select only one parameter, click it. To select more parameters, hold down Shift and click the desired parameters.
2. To deselect parameters in the selection list, hold down Shift and click the parameter.
3. Click the arrow to the right of the parameter selection box and select the parameter you wish to see in the trend box. 

Checking the latest numerical parameter value

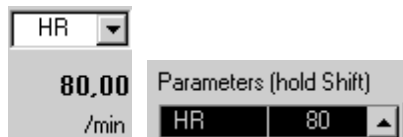

The latest read numerical parameter values are shown to the right of the trend box. They are also displayed next to the **Parameters** selection list.

Clearing the trends

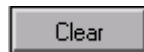

Pressing the **Clear** button clears the graphs and the display memory.

Auto-selection of displayed trends

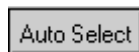

Pressing **Auto Select** will select and display all data with a significant positive value after the next data has been read.

Changing the trend sampling interval

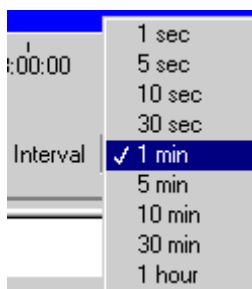

Click **Interval** and select **1 sec**, **5 sec**, **10 sec**, **30 sec**, **1 min**, **5 min**, **10 min**, **30 min** or **1 hour**.

NOTE: **1 sec** and **5 sec** not available during network connection.

When you want to see quick changes in the trends, select a short interval, for example 5 seconds. When you want to see the overall direction of the trends, select a longer interval, for example 1 minute.

Changing the trend scale



Click **Scale** and select the desired trend time scale from values **1 min**, **5 min**, **10 min**, **20 min**, **30 min**, **1 hour**, **2 hours**, **4 hours**, **6 hours**, **8 hours**, **12 hours**, **24 hours** and **Auto**. The trend boxes start showing trends using the selected scale. The start and end times under the trend panel change accordingly.

If you select **Auto**, the time scale is autoscaling all the time: the start time is the start of the collection period, or the moment the graph was cleared last, and the end time is the time of the last package received.

Showing data as XY graphs

You can show trend and waveform data also in an XY graph. To do this, select the **Trends XY** or **Waves XY** page in the main window.

For trend parameters, XY graph is an easy way to find out a correlation between different parameters. For waveforms, the XY graphs make it possible to show, for example, spirometry loops.

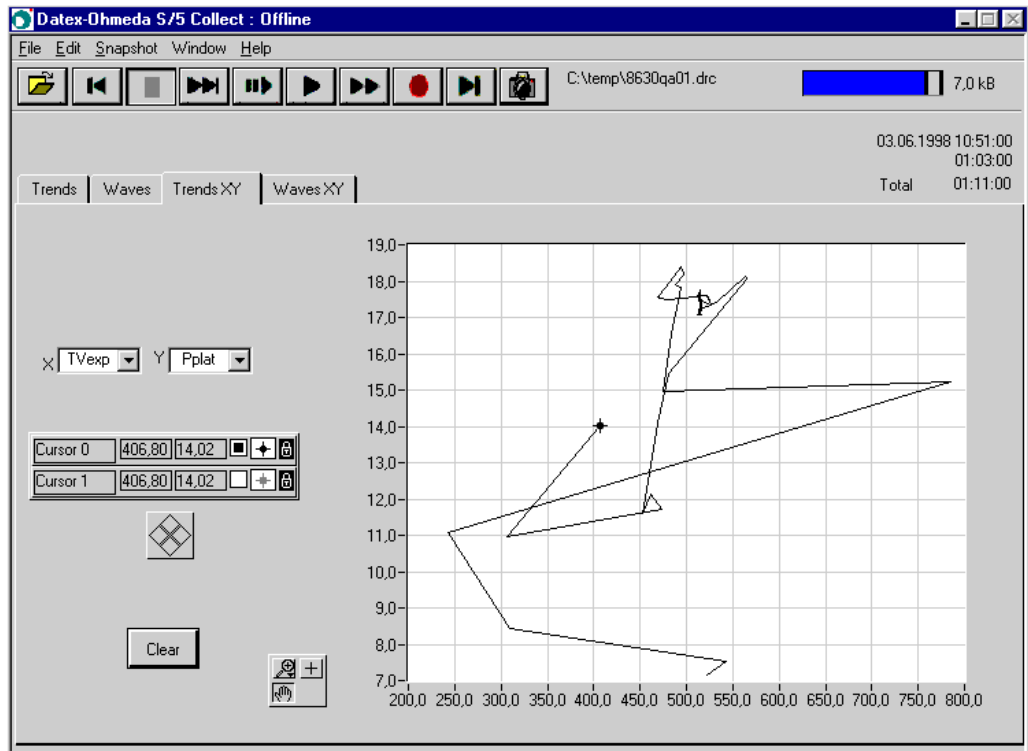

Figure 5-8 Trends XY page

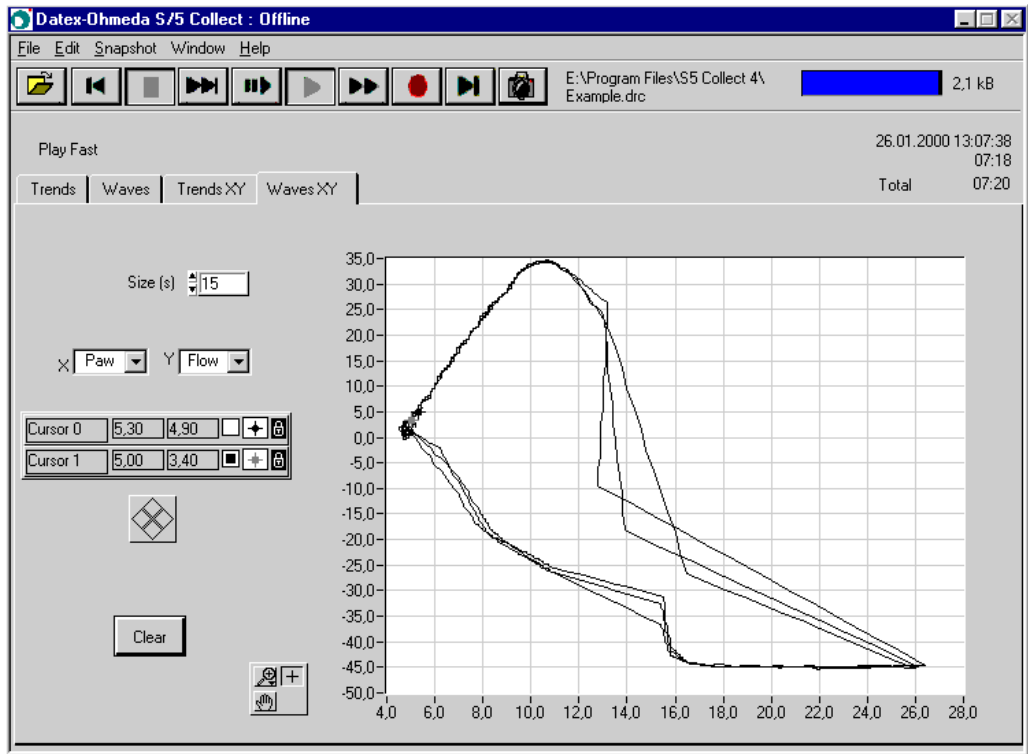
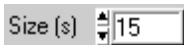

Figure 5-9 Waves XY page



You can change the displayed parameters from the parameter boxes on the left.



Change the size to have more or less history on the graph on the Waves XY page.

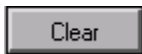

You can clear the graphs from the page and the display memory with the **Clear** button.



You can use the cursor movement tool to move the cursor.



Use the graph palette to scroll the display area of the graph and to zoom in and out of sections of the graph. See "[Appendix A: Graph palette](#)" for details.

Use the cursor legend palette for putting the cursor on the graph.

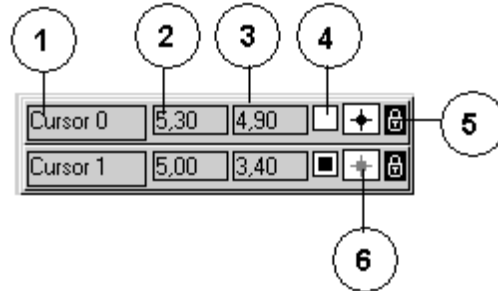

Figure 5-10 Cursor legend palette

- (1) Cursor name
- (2) Position on X axis
- (3) Position on Y axis
- (4) Button indicating the active cursor
- (5) Cursor locking control
- (6) Cursor style control

For details about the cursor legend palette, see "[Appendix A: Cursor legend palette](#)."

Moving to a specific time in the offline graphs

You can move directly to the desired time point by

- selecting **Edit - Go to time** (Ctrl+I)
- or by clicking  (F4).

The Set Time dialog is displayed.

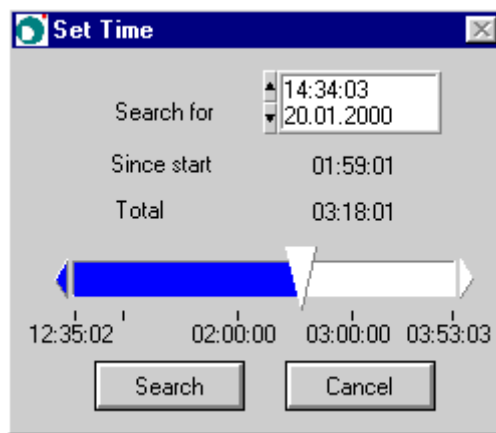

Figure 5-11 Set time dialog box

The leftmost time is the time of the first data package and the rightmost time the time of the last data package.

- Drag the bar to the desired time before or after the current time, enter the time in the **Search for** field, or use the arrow buttons in the **Search for** field to enter the desired time.
- Click **Search** to move to the desired point in the .drc file.

Once the nearest time point has been found the following dialog will be displayed.

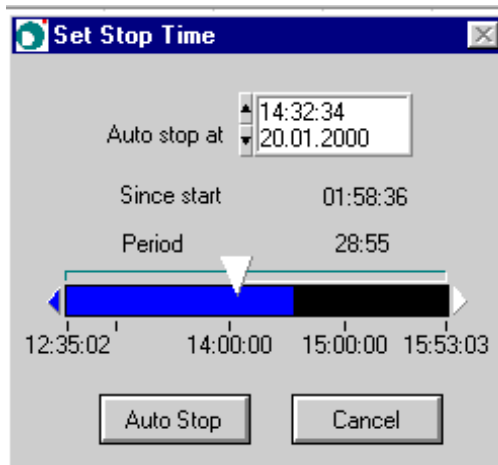

Figure 5-12 Found. What next? dialog box

- Click **Set Auto Stop Time** to go directly to the dialog for setting the auto stop time (see below). After leaving that dialog you will return to the Found. What next? dialog again.
- Click **Start Play** to start playing again at high speed. The program starts showing graphs from the selected time onwards.
- Click **Cancel** to stop at the current position.
- Click **Save to ASCII** to save all data from the current position to the auto stop time, or if auto stop time has not been set, to the end of the file.

Stopping an action at a desired time

1. To automatically stop an action at a desired time, click  (F9) or select **Edit - Auto Stop** (Ctrl+A). This can be used to stop any actions, for example, playing, winding and saving.



2. Enter the desired time by entering the time in the **Auto stop at** box or by using the slide bar.
3. Click **Auto Stop**. The auto stop time information will be shown in the upper right corner of the window. Selecting **Cancel** will close this window and also cancel a previously set auto stop time.

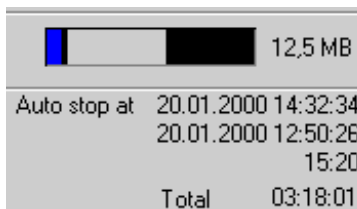

4. Once the desired time is reached, the following message is displayed. Click **OK**.

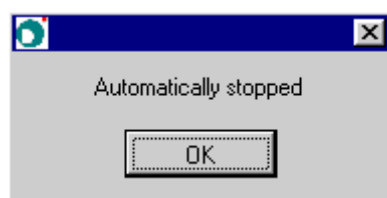

Searching for markers

You can move to the next marker in the file by selecting **Edit - Next Marker** (Ctrl+M). The program starts searching for the markers. Trends are updated during the search. Once the marker has been found, the following message is displayed:

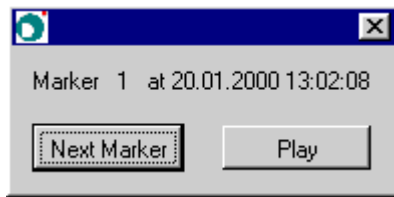

You can go to the next marker by clicking **Next Marker** or start playing the data by selecting **Play**.

NOTE: If the display interval is more than 60 times the input interval (for example, 5 min interval with dT 5 sec), markers will not be found.

The search may take a while since all trend data has to be read. You can also jump to the time of the marker by looking in the notes for the time of the marker, selecting **Edit - Go to time** (Ctrl+I) and entering the time of the marker.

Loading PHY files

You can access data that has been stored by the S/5 Central, and data on a PCMCIA card that has been used in the M-MEM module. To do this:

1. Select **File - PHYsio Database**.
2. In the Select Patient File dialog box, give the path name in the **Directory** field and click **Select Cur Dir**.

The patient data is stored on the hard disk drive of the Central in D:\Patdata. In a local office network the drive of the Central server may be mapped on the PC running the S/5 Collect to, for example, P:\Patdata.

NOTE: It is not allowed to choose the current active Central directory \PATDATA due to potential file access conflicts. It is only possible to select inactive, already archived data in the \PATDATA\ARC for patients that have already been discharged. To look at data on patients currently on the ward, copy a selection of the data in \PATDATA using, for example, Windows Explorer to a directory on your local hard disk drive. The name of the root directory on your local hard disk drive must be other than \PATDATA.

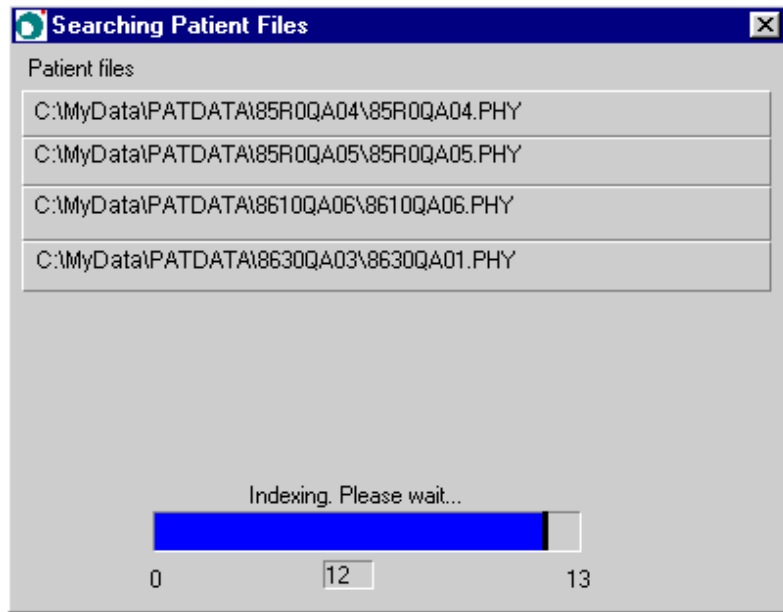

Figure 5-13 Patient file search

3. When the search is completed, the patient files are displayed in the Select Patient File window.

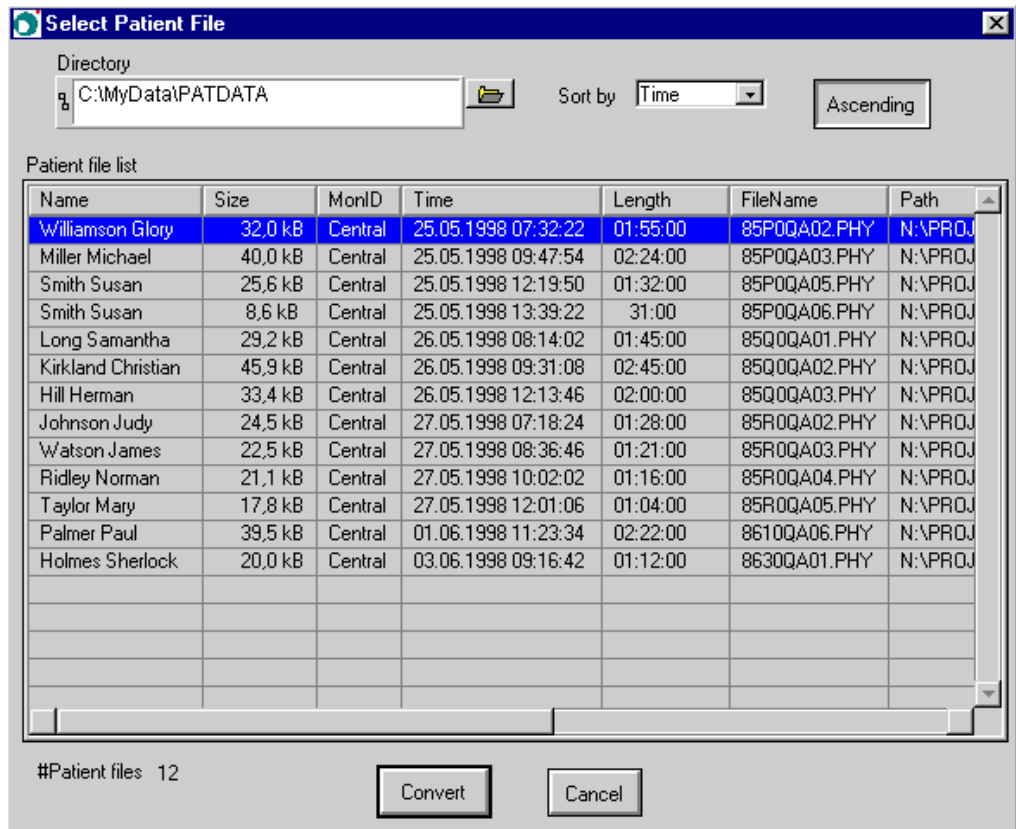

Figure 5-14 Select Patient File window showing the found files

The number of the patient files is indicated in the lower left corner of the window. You can sort the files by name, size, monitor ID, time, length, file name or path.

- To convert a file to .drc format, select it and click **Convert**. Enter the path in the Save as dialog box. The file is saved and opened in the offline mode. You can select to play it or save it in ASCII format. Events stored in the patient data directory are also converted and will be copied to the notes.

You can also find examples of data that has been stored by Central on the CD-ROM in the directory `\Patient Data\Central`.

Saving data in PHY files

To save .drc file format data in PHYsio files :

1. Open a .drc file in the offline mode.
2. Select **File - Save as - PHYsio files of 1 min trend**. Enter the path in the Export trend records to PHY directory dialog box. The file name is generated automatically.

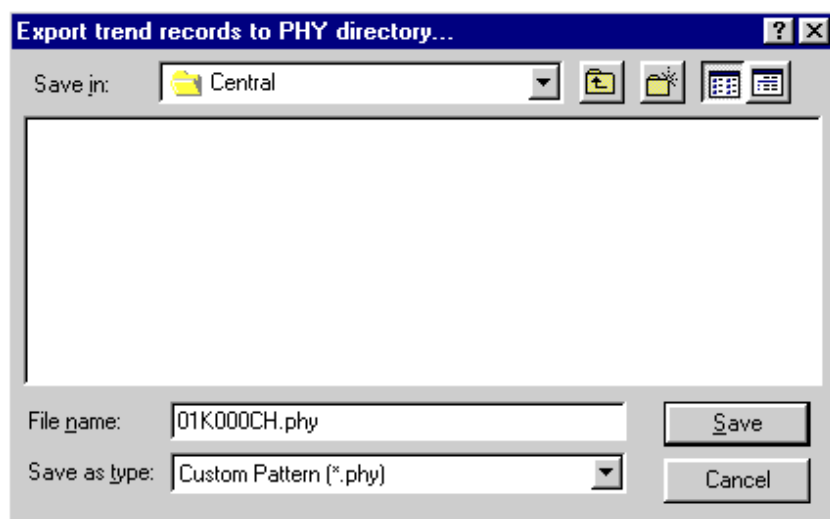

Figure 5-15 Selecting a directory for saving data in PHY files

Only trend data is saved in PHYsio files. The program saves one data record once a minute (even if the data was originally recorded at a different interval, for example 5 seconds).

NOTE: This option does not work if the .drc file contains intervals longer than 1 minute.

Saving data in .drc files

You can save data in a .drc file

- without waveforms by selecting **File - DRC file without waves**.
- with waveforms by selecting **File - DRC file with waveforms**.

You will be prompted for a file name.

Saving data in ASCII files

Saving selected data in an ASCII file

When the desired file position is displayed, click  or press F8 to start saving the trend, waveform and alarm data in ASCII files.

- Only the selected trend and waveform parameters are saved.
 - To save both trends and waveforms, click the save button while the Waves page is displayed.
 - If you do not need to save waveforms in ASCII and/or want to reduce the saving time and save only trends, click the save button while the Trends page is displayed.
 - To further reduce the saving time, select **Window - Resize** to hide the graph area during saving.
 - If alarm data was saved in the .drc file, it is displayed and saved to ASCII.
 - Data will be saved at the selected trend interval and waveform frequency. To decrease the ASCII file size, increase the trend interval or reduce the waveform frequency.
 - The selected trend scale and the period of waveform display do not have any effect on saving, but are for displaying purposes only.
 - You will be prompted for the name of the trends file, waves file and alarms file separately. By default, file names `trends.asc`, `waves.asc` and `alarms.asc` are used.
- To stop saving at the desired point, click  or press F3.

In the ASCII files, the columns are separated by tabs. The output formats are shown in "[Appendix B: File formats](#)".

NOTE: The decimal symbol saved in the ASCII file follows the Windows settings (**Start - Settings - Control Panel - Regional Settings**). Programs like Microsoft Excel also follow this setting. When transferring the ASCII files between different PCs, make sure that the decimal symbol has been set the same on all PCs.

NOTE: Unregistered applications can save only 4 lines of trend data or 10 seconds of waveform data in ASCII files.

Saving all data in an ASCII file

You can save all data in the `.drc` file in ASCII format by selecting **File - Save All**. You will be prompted for the file name.

NOTE: Saving all data is also possible without replaying the file on the screen. When you have started the program and selected **Offline** from the startup window, select **Save All to ASCII**. See page 5-2 for details.

Viewing ASCII files

Select **File - View ASCII file** to open a file that has been stored before as an ASCII file. This selection opens a `*.asc` or `*.txt` file with the default editor or viewer configured in the Windows operating system (for example Notepad).

Opening a new .drc file

At any moment, you can start working with another `.drc` file. To do this:

- select **File - Open** (Ctrl+O)

or

- click  (F1).

Locate the new file and open it. The program closes the previous file and starts reading the new one.

Printing

You can print the currently displayed data on your default printer by selecting **File - Print Screen** (Ctrl+ P).

Taking snapshots

You can take the snapshots

- by selecting **Snapshots - Trends** (Ctrl+T) or **Waves** (Ctrl+W)

or

- by clicking  (F10).

The functionality of the snapshot pages is basically the same as in the online mode. See section "Taking snapshots" on page 4-17 for details.

Notes

You can view and edit case notes by selecting **Edit - Notes** (Ctrl+N) in the main offline window. The functionality of the note editor is basically the same as in the online mode. See section "[Entering and modifying notes](#)" on page 4-15 for details.

Using plug-ins

You can use the plug-ins in the same way as in the online mode. For instructions, see section "[Using plug-ins](#)" on page 4-27 and "[Appendix C: Plug-ins](#)."

Exiting the offline mode

In the main window, select **File - Exit** (Ctrl+Q) or press Esc. The S/5 Collect startup window is displayed. Now you can exit the program, start serial communication or go to online mode.

6 Help and troubleshooting

Getting help

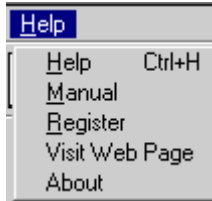

Figure 6-1 Help menu

Getting context-sensitive help

Selecting **Help - Help** displays context-sensitive help for different parts of the S/5 Collect window. The help text is displayed in a separate help panel, and the text changes according to the cursor position.

If there is a key combination or function key connected to the function, it is indicated in the help panels. Below is an example of a help panel. In this example, the cursor is currently pointing the **Waveforms** list on the Waves page.

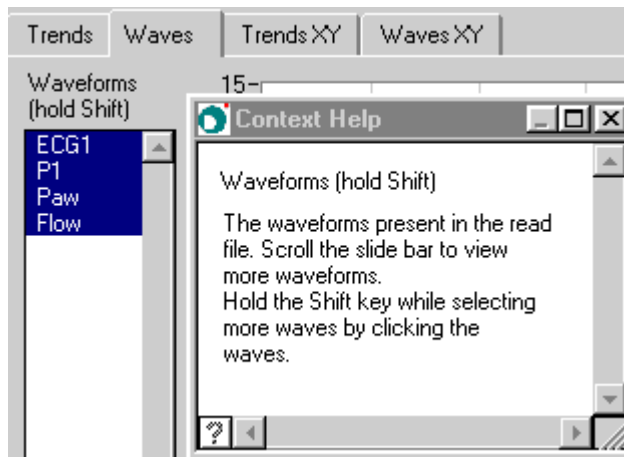

Figure 6-2 Example of a Context Help window

Displaying the manual

To display this manual in .pdf format, select **Help - Manual**. The manual can also be found in on the product CD-ROM in the directory \Documents.

Showing registration information

If you have registered the application and entered your password and select **Help - Register**, the Register window with the text 'This is a registered version' is displayed. The password field is protected.

If you have not registered your application, a prompt for registering the application and entering the password is displayed.

Displaying Datex-Ohmeda web site

To go to the Datex-Ohmeda web site, select **Help - Visit Web Page**.

Showing program information

Selecting **Help - About** shows the program version and the program generation date.

Error situations

The S/5 Collect program may be interrupted by other applications, and can run in the background. If other applications use a lot of CPU time, there is a risk that communication buffers get overloaded. This may also be the case if the program is run on a slow PC (< 200 MHz Pentium).

RS232 Communication buffer indicator bar

In the upper right corner an indicator bar displays the status of the RS232 communication buffers.

- The presence of a **green** bar indicates data has been received from the monitor but some data is being buffered. If the green bar disappears, all buffered data has been processed.
- The size of the **yellow** bar indicates how much data has been read by the software but not displayed on the screen yet. The data has not been fully processed, usually due to too heavy CPU load. If more than 10 kB is buffered, an overload message is displayed.
- The size of the **red** bar indicates how much data has been received but not read yet at all (maximum buffer size is 30kB).

Error messages

If there is a communication failure between the PC and the connected Datex-Ohmeda monitor, a corresponding error message is displayed on the top.

If for some reason the data is not received intact from the connected Datex-Ohmeda monitor, a corresponding error message is displayed on the top. The error message disappears automatically when the communication restarts normally.

Possible error messages:

Message	Cause and solution
'Communication Timeout'	No data received for 5 seconds. Check the cable (order number 881167). Check the monitor and make sure no other PC applications reserve the communication port.
'Package Length Error'	Package size does not correspond to header information. Check that the cable is connected properly.
'Checksum Error'	Calculated checksum does not correspond to checksum send with package. Check that the cable is connected properly.

Unexpected errors

If you get an unexpected error that you cannot solve yourself using this documentation, please write down the error code, restart the program and try again. If the same error appears again, please contact the local Datex-Ohmeda technical support and give the error code.

7 Editing the database configuration

NOTE: The configuration does not usually need to be changed by the users. If you need to add a new parameter or a waveform, please consult your Datex-Ohmeda representative.

The database configuration including the current selections is saved in the program directory in configuration files `params.txt` and `waves.txt` each time when you exit the program. See "[Params.txt](#)" and "[Waves.txt](#)" in "Appendix B" for the contents of these two files.

Select **Edit - Configuration** in the online or offline mode. The Configuration Editor is displayed.

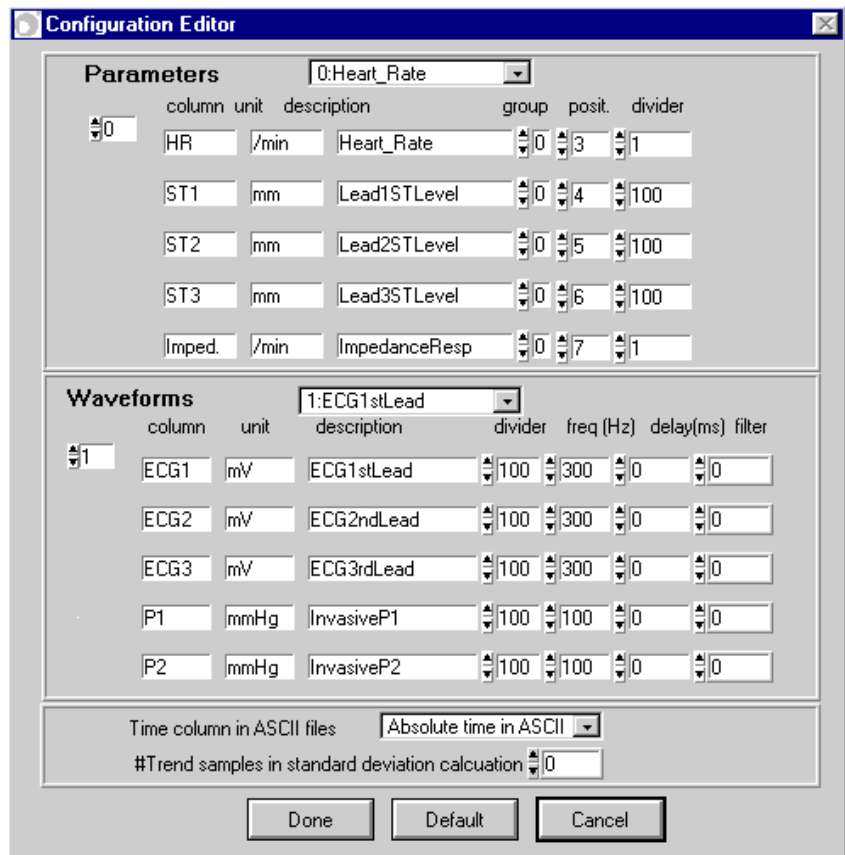

Figure 7-1 Configuration Editor window

Parameters

Use the trend box  or the selection box  to display the desired parameters.

For parameters, the column, unit, description, group, position and divider settings are given.

The value in the **column** indicates the label shown in parameter selection lists and ASCII files.

The **description** is only shown in the Configuration Editor window.



NOTE: You can change the **column** and **description** values. It may be that additional parameters or waveforms have been added to a monitor after the release of this collection program. When adding new parameters, you can also add data to other fields. When adding new parameters, please consult your Datex-Ohmeda representative.

NOTE: Special caution should be taken with the group and position settings.

The monitor sends the parameter data in packages of several parameters. A **group** means the numerical code of the package of parameters the parameter belongs to. A **position** refers to the parameter's position in a specific group.

The **divider** setting depends on the unit in use. The divider modifies the data string given by the monitor into physiological values.

Waveforms

Use the waveform box  or the selection box  to display the desired waveforms.

For waveforms, the column, unit, description, divider, frequency, delay and filter settings are given.

NOTE: Do not change any values in the existing fields. You may add new waveforms in the configuration. When adding new waveforms, please consult your Datex-Ohmeda representative.

The value in the **column** indicates the label shown in waveform selection lists and ASCII files.

The **description** is only shown in the Configuration Editor window.

The **divider** setting depends on the unit in use.

The **frequency** is defined by the monitor.

The **delays** are used for synchronizing data on the screen, in the XY graphs and in the saved ASCII files. The waveform delay for gas is set to 2 seconds; this is the default for a 3-meter sampling line. If the waves are generated by mainstream CO₂ (Light Monitor), the delay should be set to 0.

If a negative number is used for the **filter**, it will fasten the waveform. A positive number will slow down the waveform.

Time format for ASCII files



The **Time column in ASCII files** selection box defines how the time in the time column in the trend ASCII files is formatted. **Absolute time in ASCII** will make a string according to the Regional settings as defined in Windows Control Panel. With **Relative to start** the time is cumulative from the start of the time of saving. **Time in unix format** will use unix format in indicating the time.

Defining the digit field color behavior

The color of the digit fields on the main window Trend page indicates the stability of trend data. The color selection is affected by the value in the **#Trend samples in standard deviation calculation** box. In this box, enter the number of trend values to be included in standard deviation calculation. The number indicates the number of samples.

Ranges for coloring the digit fields are the following:

0 to 2.5%	Green
2.5 to 5%	White
5 to 10%	Yellow
10% or higher	Red

You may use this feature to establish a steady state for selecting the moment to start collecting data.

APPENDIX A: Using LabVIEW palettes

NOTE: The following is a modified version of the instructions given in the LabVIEW help pages. LabVIEW is a registered trademark of National Instruments Corporation. For more information about using LabVIEW, see LabVIEW manuals in www.ni.com.

Click the right mouse button and select **Visible Items**.

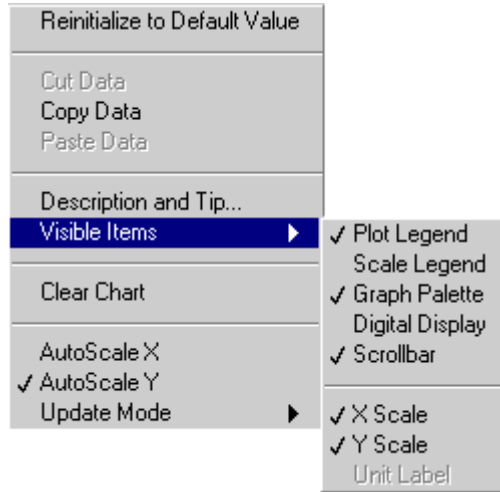

Plot Legend palette

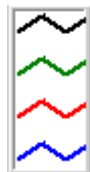

To display or hide the Plot Legend palette, click the right mouse button and select **Visible Items - Plot Legend**. Right-click a wave in the palette to show the commands available for formatting the plot on the screen.



- To change the type of the plot, click **Common Plots**.

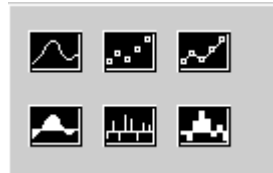

- To change the color of the plot, select **Color**.

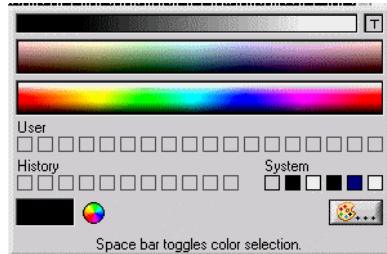

- To select a new style for the plot line, select **Line Style**.

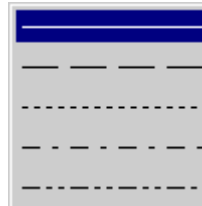

- To select a new width for the plot line, select **Line Width**.

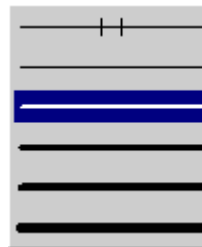

- Select **Anti-Aliased** to add a low pass filter (a filter that passes low frequencies but attenuates the high frequencies) before the sampler and the ADC. By attenuating the higher frequencies, it prevents the aliasing components from being sampled.

- To show the data as a bar plot, select **Bar Plots** and the desired bar plot style.

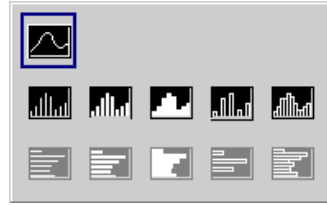

- To change the way the bars are displayed in reference to the baseline, select **Fill Base Line**.

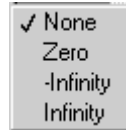

- To select the style for drawing the lines between samples, select **Interpolation**.

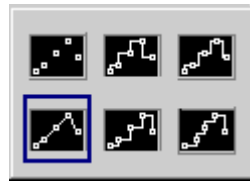

Scale legend palette

To display or hide the Scale Legend palette, click the right mouse button and select **Visible Items - Scale Legend**. With this palette, you can format the X and Y scales of a graph. By using the palette, you can maintain run-time control over the format of the X and Y scale markers respectively.



Scale Legend palette on All snapshots page



Scale Legend palette on One snapshots page

The first scale from the top of the palette on the All page is the X scale and the second is the Y scale of the first graph from the top, the third is the Y scale of the second graph from the top, etc.

If you want the graph to autoscale either of the scales continuously, click on the lock switch, to lock autoscaling on.

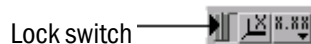

Click the scale you want to format. This opens the formatting menu for that scale. 

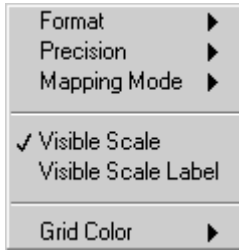

- To select the numeric format of the data shown on X or Y axis select **Format** and one of the options. The default for the X scale is **Absolute Time**, and the default for the Y scale is Decimal.

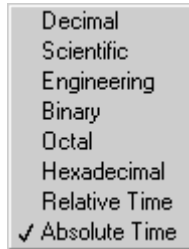

- To define how precise information you wish to show, select **Precision** and one of the values.

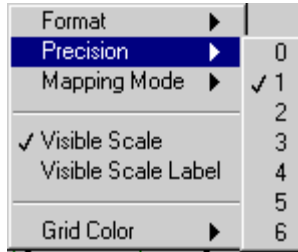

- To change the mapping mode, select **Mapping Mode** and **Linear** (default) or **Logarithmic**. You can change the mapping mode only on the Y scale.

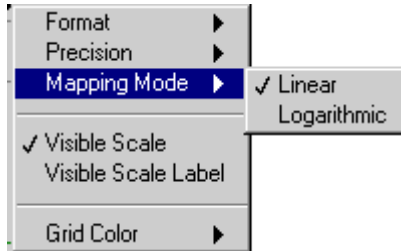

- To show the scale for the select axis, select **Visible Scale**. The scale is displayed by default.
- To change the color of the grid, select **Grid Color**.

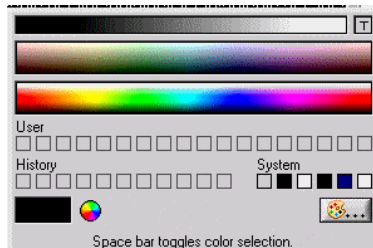



Graph palette

To display or hide the Graph palette, click the right mouse button and select **Visible Items - Graph Palette**. The Graph Palette has controls for panning (scrolling the display area of a graph) and for zooming in and out of sections of the graph.



Use the cursor movement tool  to move the cursor on the graph.

Use the panning tool  to pick up the plot and move it around on the screen.

The Zoom tool  allows you to zoom in or out on the graph. If you click the Zoom tool, you see a pop-up menu to choose methods of zooming.

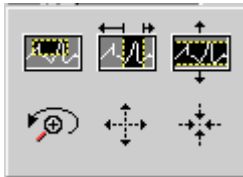

Zoom by rectangle.



Zoom by rectangle, with zooming restricted to x data (the y scale remains unchanged).



Zoom by rectangle, with zooming restricted to y data (the x scale remains unchanged).



Undo last zoom. Resets the graph to its previous setting.



Zoom in about a point. If you hold down the mouse on a specific point, the graph continuously zooms in until you release the mouse button.



Zoom out about a point. If you hold down the mouse on a specific point, the graph continuously zooms out until you release the mouse button.

NOTE: For the last two modes, zoom in and zoom out about a point, clicking Shift zooms in the other direction.

Cursor legend palette

To display or hide the Cursor legend palette, right-click the mouse and select **Visible Items - Cursor Legend**.

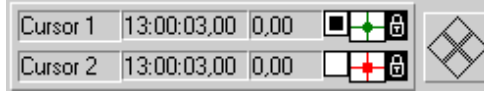

The Cursor palette used for putting cursors on the graph. You can label the cursor on the plot, and use a cursor as a marker. When you use a cursor as a marker, you lock the cursor to a data plot so the cursor follows the data.

Each cursor for a graph has the following parts.



The cursor label. You can change the name by entering a new name in the box.

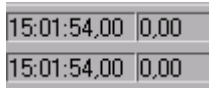

X and Y coordinates.

A button that marks the plot for movement with the plot cursor pad.

A button that controls the look of the cursor. The following selections are available:

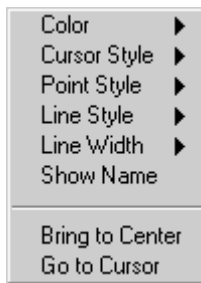

A lock control button that determines if the cursor is locked to a plot or moved freely. The following selections are available:

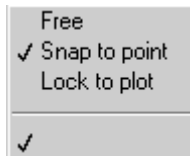

Cursor movement tool.

APPENDIX B: File formats

Configuration files

The configuration files are located in the program directory. Each file may be edited with spreadsheet programs like Excel.

NOTE: Be very careful when adding or making changes in database definition files. Before doing so, please consult your Datex-Ohmeda representative.

Params.txt

This file contains the parameter definitions.

Sel	Gr	Pos	Div	Name	Unit	Description
2	0	3	1	HR	/min	Heart_Rate
0	0	4	100	ST1	mm	Lead1STLevel
1	0	5	100	ST2	mm	Lead2STLevel
0	0	6	100	ST3	mm	Lead3STLevel
0	0	7	1	Imped.	/min	ImpedanceResp
2	0	11	100	P1sys	mmHg	P1Systolic
1	0	12	100	P1dia	mmHg	P1Diastolic
1	0	13	100	P1mean	mmHg	P1Mean
1	0	14	1	PR(P1)	/min	P1PulseRate
1	0	18	100	P2sys	mmHg	P2Systolic
1	0	19	100	P2dia	mmHg	P2Diastolic
1	0	20	100	P2mean	mmHg	P2Mean
1	0	21	1	PR(P2)	/min	P2PulseRate
0	0	25	100	P3sys	mmHg	P3Systolic
0	0	26	100	P3dia	mmHg	P3Diastolic
0	0	27	100	P3mean	mmHg	P3Mean
0	0	28	1	PR(P3)	/min	P3PulseRate
1	0	32	100	P4sys	mmHg	P4Sys
1	0	33	100	P4dia	mmHg	P4Diastolic
1	0	34	100	P4mean	mmHg	P4Mean
1	0	35	1	PR(P4)	/min	P4PulseRate
0	0	39	100	NIBPsys	mmHg	NonInvBPSystolic
0	0	40	100	NIBPdia	mmHg	NonInvBPDiastolic
0	0	41	100	NIBPmean	mmHg	NonInvBPMean
0	0	42	1	PR(NIBP)	/min	NonInvBPHeartRate
0	0	46	100	T1	C	Temperature1
1	0	50	100	T2	C	Temperature2
0	0	54	100	T3	C	Temperature3
0	0	58	100	T4	C	Temperature4

Sel	Gr	Pos	Div	Name	Unit	Description
0	0	62	100	SpO2	%	SpO2
0	0	63	1	PR(SpO2)	/min	SpO2PulsRate
0	0	64	100	SpO2_ir	%	InfraRedAmplitude
0	0	65	100	SvO2p	%	SvO2(SpO2)
2	0	69	100	EtCO2	%	CO2EndTidal
1	0	70	100	FiCO2	%	CO2InspFraction
1	0	71	1	RR(CO2)	/min	CO2RespRate
1	0	72	10	Pamb	mmHg	AmbientPressure
1	0	76	100	FeO2	%	O2ExpFraction
1	0	77	100	FiO2	%	O2InspFraction
1	0	81	100	FeN2O	%	N2OExpFraction
0	0	82	100	FiN2O	%	N2OInspFraction
0	0	86	100	FeAA	%	AgentExpFraction
0	0	87	100	FiAA	%	AgentInspFraction
0	0	88	100	MAC	-	AgentMacSum
1	0	92	1	RR(Spiro)	/min	SpiroRespRate
1	0	93	100	Ppeak	cmH2O	Ppeak
1	0	94	100	PEEP	cmH2O	PEEP
1	0	95	100	Pplat	cmH2O	Pplat
1	0	96	10	TVinsp	ml	TidalVolInsp
2	0	97	10	TVexp	ml	TidalVolExp
1	0	98	100	Compl	ml/cmH2O	Compliance
1	0	99	100	MVexp	L/min	MinuteVolExp
1	0	103	1000	C.O.	L/min	CardiacOutput
1	0	104	100	Tblood	C	BloodTemperature
0	0	105	100	RVEF	%	RightVentrEjectFraction
1	0	106	100	PCWP	mmHg	PulmWedgePress
0	0	110	10	T1%	%	NMT1
0	0	111	10	TOF%	%	TrainOfFourPerc
0	0	112	1	PTC	-	PTC
1	0	113	1	HR(ECG)	/min	ECGhr
1	0	114	1	HRmax	/min	HeartRateMax
1	0	115	1	HRmin	/min	HeartRateMin
0	0	119	100	SvO2	%	SvO2
0	0	123	100	P5sys	mmHg	P5Systolic
0	0	124	100	P5dia	mmHg	P5Diastolic
0	0	125	100	P5mean	mmHg	P5Mean
0	0	126	1	PR(P5)	/min	P5PulseRate
0	0	130	100	P6sys	mmHg	P6Systolic
0	0	131	100	P6dia	mmHg	P6Diastolic
0	0	132	100	P6mean	mmHg	P6Mean
0	0	133	1	PR(P6)	/min	P6PulseRate
0	0	135	1	Marker	0x00FF	Marker

Sel	Gr	Pos	Div	Name	Unit	Description
1	1	3	1	HR(aECG)	/min	ArrhHeartRate
0	1	4	1	RRt(aECG)	mmHg	ArrhRRTime
0	1	5	1	PVC	-	PVC
0	1	6	1	aStatus	-	ArrhStatus
0	1	25	100	ST(I)	mm	ST(I)
1	1	26	100	ST(II)	mm	ST(II)
0	1	27	100	ST(III)	mm	ST(III)
0	1	28	100	ST(AVL)	mm	ST(AVL)
0	1	29	100	ST(AVR)	mm	ST(AVR)
0	1	30	100	ST(V1)	mm	ST(V1)
0	1	31	100	ST(V2)	mm	ST(V2)
0	1	32	100	ST(V3)	mm	ST(V3)
0	1	33	100	ST(V4)	mm	ST(V4)
0	1	34	100	ST(V5)	mm	ST(V5)
0	1	35	100	ST(V6)	mm	ST(V6)
1	2	3	1	NMT(Count)	-	NMTcount
1	2	4	1	NMT(R1)	-	NMTTrainResponse1
1	2	5	1	NMT(R2)	-	NMTt2
1	2	6	1	NMT(R3)	-	NMTt3
1	2	7	1	NMT(R4)	-	NMTt4
0	2	15	10	FEMG	uV	FrontalEMG
0	2	16	10	Ampl1	uV	Ampl1
0	2	17	10	SEF1	Hz	Sef1
0	2	18	10	MF1	Hz	MF1
0	2	19	1	Delta1	%	Delta%1
0	2	20	1	Theta1	%	Theta%1
0	2	21	1	Alpha1	%	Alpha%1
0	2	22	1	Beta1	%	Beta%1
0	2	23	1	BSR1	%	BSR1
0	2	24	10	Ampl2	uV	Ampl2
0	2	25	10	SEF2	Hz	Sef2
0	2	26	10	MF2	Hz	MF2
0	2	27	1	Delta2	%	Delta%2
0	2	28	1	Theta2	%	Theta%2
0	2	29	1	Alpha2	%	Alpha%2
0	2	30	1	Beta2	%	Beta%2
0	2	31	1	BSR2	%	BSR2
0	2	32	10	Ampl3	uV	Ampl3
0	2	33	10	SEF3	Hz	Sef3
0	2	34	10	MF3	Hz	MF3
0	2	35	1	Delta3	%	Delta%3
0	2	36	1	Theta3	%	Theta%3
0	2	37	1	Alpha3	%	Alpha%3

Sel	Gr	Pos	Div	Name	Unit	Description
0	2	38	1	Beta3	%	Beta%3
0	2	39	1	BSR3	%	BSR3
0	2	40	10	Ampl4	uV	Ampl4
0	2	41	10	SEF4	Hz	Sef4
0	2	42	10	MF4	Hz	MF4
0	2	43	1	Delta4	%	Delta%4
0	2	44	1	Theta4	%	Theta%4
0	2	45	1	Alpha4	%	Alpha%4
0	2	46	1	Beta4	%	Beta%4
0	2	47	1	BSR4	%	BSR4
0	2	51	1	BIS	-	BIS
0	2	52	1	BisSQI	%	BisSignalQualityIndex
0	2	53	1	BisEMG	dB	BisEMG
0	2	54	1	BisSR	-	BisSuppRatio
1	2	59	1	SE	-	StateEntropy
1	2	60	1	RE	-	ResponseEntropy
1	2	61	1	BSR	-	BSR
1	3	3	10	VO2	ml/min	O2consumption
1	3	4	10	VCO2	ml/min	CO2production
1	3	5	1	EE	kcal/day	EnergyExpenditure
1	3	6	1000	RQ	-	RespQuotient
1	3	10	100	PEEPi	cmH2O	IntrinsicPEEP
1	3	11	100	Pmean	cmH2O	Pmean
0	3	12	100	Raw	cmH2O/L/s	AirwayResistance
1	3	13	100	MVinsp	L/min	MinuteVollInsp
1	3	14	100	PEEPe	cmH2O	ExtrinsicPEEP
1	3	15	100	MVspont	L/min	SpontMinVol
0	3	16	100	I:E	-	RatioInspExpTime
0	3	17	100	Tinsp	sec	InspTime
1	3	18	100	Texp	sec	ExpTime
1	3	19	100	StCompl	ml/cmH2O	StaticCompliance
0	3	20	100	StPplat	cmH2O	StaticPplat
0	3	21	100	StPEEPe	cmH2O	StaticPEEPe
0	3	22	100	StPEEPi	cmH2O	StaticPEEPi
0	3	33	100	FeBal	%	BalanceGasFe
0	3	34	100	FiBal	%	BalanceGasFi
0	3	38	100	PgCO2	kPa	TonometryCO2
0	3	39	100	EtPgCO2	kPa	EndTidalCO2
0	3	40	100	PaCO2	mmHg	ArterialCO2
0	3	41	1	Delay	sec	Delay
0	3	42	100	pHi	pH	pHi
1	3	43	1	pHiDelay	sec	pHiDelay
0	3	44	10	Pamb	mmHg	AmbientPressure

Sel	Gr	Pos	Div	Name	Unit	Description
1	3	45	1	CPMA	-	CPMA
1	3	49	100	MACage	-	AgentMACageSum
0	0	1	1	Free1	-	Free1
0	0	1	1	Free2	-	Free2
0	0	1	1	Free3	-	Free3
0	0	1	1	Free4	-	Free4
0	0	1	1	Free5	-	Free5

Waves.txt

This file contains the waveform definitions.

Sel	Freq.	Delay	Divider	Filter	Column	Unit	Description
2	100	0	1	1	None	-	None
0	300	0	100	0	ECG1	mV	ECG1stLead
0	300	0	100	0	ECG2	mV	ECG2ndLead
0	300	0	100	0	ECG3	mV	ECG3rdLead
0	100	0	100	0	P1	mmHg	InvasiveP1
0	100	0	100	0	P2	mmHg	InvasiveP2
0	100	0	100	0	P3	mmHg	InvasiveP3
0	100	0	100	0	P4	mmHg	InvasiveP4
0	100	0	100	0	Pleth	%	Plethysmogram
0	25	2000	100	0	CO2	%	CO2
0	25	2000	100	0	O2	%	O2
0	25	2000	100	0	N2O	%	N2O
0	25	2000	100	0	AA	%	AnestheticAgent
0	25	500	10	0	Paw	cmH2O	AirwayPressure
0	25	500	10	0	Flow	L/min	Flow
0	25	0	100	0	Resp	Ohm	ImpedanceResp
0	100	0	100	0	P5	mmHg	InvasiveP5
0	100	0	100	0	P6	mmHg	InvasiveP6
0	100	0	10	0	EEG1	uV	EEG1
0	100	0	10	0	EEG2	uV	EEG2
0	100	0	10	0	EEG3	uV	EEG3
0	100	0	10	0	EEG4	uV	EEG4
0	3000	0	1	0	RES0	-	Res0
0	25	500	1	0	Vol	ml	Volume
0	25	0	10	0	Ptono	cmH2O	TonometerPressure
0	25	0	10	0	PawVent	cmH2O	PawVent
0	25	0	10	0	FlowVent	L/min	FlowVent
0	25	0	1	0	VolVent	ml	VolVent
0	100	0	100	0	NIBPcuff	mmHg	NonInvCuffPress
0	25	500	1	0	SpiroStatus	-	SpiroLoopInsp
0	100	0	10	0	EP	uV	EvokePotential
0	400	0	1	0	PlethC	-	PlethComposite
0	100	0	10	0	Ent100	uV	Entropy100Hz
0	400	0	40	0	Ent400	uV	Entropy400Hz
0	100	0	1	0	RES1	-	Res1
0	100	0	1	0	RES2	-	Res2
0	100	0	1	0	RES3	-	Res3
0	100	0	1	0	RES4	-	Res4
0	100	0	1	0	????	-	Unknown

ASCII output files

Alarms.asc

Time	ID	Prio	Sound	Type	Priority	Box1	Box2	Box3	Box4	Box5
10:04:19				Status Alarm	White alarm	Apnea				
10:04:56	300	1	0	Status Alarm	White alarm	Apnea				
10:05:14	300	0	0	Status Alarm	Alarm is not active					
10:05:16	303	1	0	Status Alarm	White alarm	SpO2 probe off				
10:05:30	303	0	0	Status Alarm	Alarm is not active					
10:05:46	303	1	0	Status Alarm	White alarm	SpO2 probe off				
10:05:50	303	0	0	Status Alarm	Alarm is not active					
10:06:00	28	2	0	Status Alarm	Yellow alarm	Tachy				
10:06:04	28	0	0	Status Alarm	Alarm is not active	Brady				
10:06:04	27	2	0	Status Alarm	Yellow alarm	Brady				
10:06:08	27	0	0	Status Alarm	Alarm is not active					
10:06:48	524	1	0	High Limit Alarm	White alarm	EtCO2 high				
10:06:54	524	0	0	High Limit Alarm	Alarm is not active					
10:07:18	524	1	0	Low Limit Alarm	White alarm	EtCO2 low				
10:07:28	524	0	0	Low Limit Alarm	Alarm is not active					
10:07:58	28	2	1	Status Alarm	Yellow alarm	Tachy	Resp high			
10:07:58	523	1	1	High Limit Alarm	White alarm	Tachy	Resp high			
10:08:10	524	1	1	High Limit Alarm	White alarm	Tachy	Resp high	EtCO2 high		
10:08:14	522	2	1	High Limit Alarm	Yellow alarm	Tachy	SpO2 high	Resp high	EtCO2 high	

10:08:38	523	2	1	High Limit Alarm	Yellow alarm	Tachy	SpO2 high	Resp high	EtCO2 high	
10:08:48	524	2	1	High Limit Alarm	Yellow alarm	Tachy	SpO2 high	Resp high	EtCO2 high	
10:09:06	28	3	1	Status Alarm	Red alarm	Tachy	SpO2 high	Resp high	EtCO2 high	
10:09:16	522	3	1	High Limit Alarm	Red alarm	Tachy	SpO2 high	Resp high	EtCO2 high	
10:09:22	534	2	1	Low Limit Alarm	Yellow alarm	Tachy	SpO2 high	Resp high	EtCO2 high	MVexp low
10:10:00	28	0	0	Status Alarm	Alarm is not active	FiO2 low				
10:10:00	522	0	0	High Limit Alarm	Alarm is not active	FiO2 low				
10:10:00	523	0	0	High Limit Alarm	Alarm is not active	FiO2 low				
10:10:00	524	0	0	High Limit Alarm	Alarm is not active	FiO2 low				
10:10:00	534	0	0	Low Limit Alarm	Alarm is not active	FiO2 low				
10:10:00	527	2	0	Low Limit Alarm	Yellow alarm	FiO2 low				
10:10:10	527	0	0	Low Limit Alarm	Alarm is not active					

Below is a list of alarm IDs and the corresponding alarms. This list may be useful for you when you are reading the `alarms.asc` file.

ID	Alarm
1	Asystole
2	Ventricular fibrillation
3	Rapid ventricular tachycardia
4	Ventricular tachycardia
5	Extreme bradycardia
6	Extreme tachycardia
7	PVC run >3
8	PVC triplet
9	PVC couplet
10	R-on-T PVC
11	Idioventricular rhythm
12	Ventricular bigeminy
13	Ventricular trigeminy
14	Frequent PVCs
15	Multifocal PVCs
16	Supraventricular tachycardia
17	Frequent SVCs
18	Missing beat
19	Unclassified arrhythmia
20	Noisy ECG
21	Problem QRS
22	Low amplitude
23	Salvo
24	Pacer non-functional
25	Pacer non-capture
26	New QRS
27	Bradycardia
28	Tachycardia
29	Long R-to-R interval
30	R-to-R interval
31	PVCs/min
300	Apnea
301	Apnea disconnection
302	Occlusion
303	SpO2 probe off
304	SpO2 check probe
305	No SpO2 probe
306	No SpO2 pulse
307	NIBP cuff loose

ID	Alarm
308	NIBP air leakage
309	NIBP cuff occlusion
310	EtN2O >= 82
311	EtAA > 3 MAC
312	No QRS detected
313	No Art pulse
314	Transducer off
315	Check resp cable
316	Air leak
317	Flow disconnection
318	No P1 transducer
319	No P2 transducer
320	No P3 transducer
321	No P4 transducer
322	No P5 transducer
323	No P6 transducer
324	NMT alarm
325	SvO2 cable off
326	SvO2 poor signal
327	SvO2 temp error
328	Leads off
329	Batt low 1
330	Batt low 2
331	Network down 1
332	Network down 2
333	Network down 3
334	Network down 4
335	All source monitors disconnected
336	Source monitor 1 disconnected
337	Source monitor 2 disconnected
338	Source monitor 3 disconnected
339	Source monitor 4 disconnected
340	Source monitor 5 disconnected
341	No CO2 sensor
342	CO2 sensor failure
343	Unspecified CO2 sensor
344	CO2 adapter blocked
345	Faulty probe
346	Check NIBP

ID	Alarm
500	HR
501	NIBP sys
502	NIBP dia
503	NIBP mean
504	P1 sys
505	P1 dia
506	P1 mean
507	P2 sys
508	P2 dia
509	P2 mean
510	P3 sys
511	P3 dia
512	P3 mean
513	P4 sys
514	P4 dia
515	P4 mean
516	P5 sys
517	P5 dia
518	P5 mean
519	P6 sys
520	P6 dia
521	P6 mean
522	SpO2

ID	Alarm
523	Resp
524	EtCO2
525	FiCO2
526	EtO2
527	FiO2
528	EtN2O
529	FiN2O
530	EtAA
531	FiAA
532	Ppeak
533	TV
534	MV
535	PEEP
536	TEMP1
537	TEMP2
538	SvO2
539	Tblood
540	ST1
541	ST2
542	ST3
543	SaO2
544	iPEEP
545	ePEEP

Waves.asc

26.01.2000 13:04:14	300	Hz	948891854
ECG1	P1	Paw	Flow
-0,62	67,57	4,80	1,70
-0,63	67,57	4,80	1,70
-0,63	67,57	4,80	1,70
-0,64	67,11	4,80	1,70
-0,65	67,11	4,80	1,70
-0,66	67,11	4,80	1,70
-0,66	66,78	4,80	1,70
-0,67	66,78	4,80	1,70
-0,68	66,78	4,80	1,70
-0,68	66,55	4,80	1,70
-0,64	66,55	4,80	1,70
-0,60	66,55	4,80	1,70
-0,60	66,44	4,70	1,90
-0,67	66,44	4,70	1,90
-0,86	66,44	4,70	1,90
-1,15	66,33	4,70	1,90
-1,44	66,33	4,70	1,90
-1,62	66,33	4,70	1,90
-1,49	66,22	4,70	1,90
-0,93	66,22	4,70	1,90
0,04	66,22	4,70	1,90
1,19	66,10	4,70	1,90
2,22	66,10	4,70	1,90
2,85	66,10	4,70	1,90
2,87	65,76	4,80	0,90
2,26	65,76	4,80	0,90
1,13	65,76	4,80	0,90
-0,23	65,43	4,80	0,90
-1,53	65,43	4,80	0,90
-2,49	65,43	4,80	0,90
-3,00	64,98	4,80	0,90
-3,12	64,98	4,80	0,90

Trends.asc

NOTE: Values below -32000 have a special meaning:

- 32764 The data exceeds lower valid limit.
- 32767 There is no valid data.
- 32766 Data is not updated
- 32765 Data discontinuity (calibration ...).
- 32764 Data exceeds lower valid limit.
- 32763 Data exceeds upper valid limit.
- 32762 Data is not calibrated.
- 32699 Data discontinuity range end.
- 32500 Data discontinuity range start.

11.12.2002 13:26:43

Trend

1039613203

Time	SpO2	SpO2hr	CO2Et	CO2rr
0.00	99.00	59.00	5.06	15.00
8.00	99.00	55.00	5.24	15.00
9.00	99.00	55.00	5.24	15.00
10.00	99.00	55.00	5.24	15.00
11.00	99.00	55.00	5.24	15.00
12.00	99.00	55.00	5.16	15.00
13.00	99.00	55.00	5.16	15.00
14.00	99.00	55.00	5.16	15.00
15.00	99.00	56.00	5.16	15.00
16.00	99.00	56.00	4.95	14.00
17.00	99.00	56.00	4.95	14.00
18.00	99.00	56.00	4.95	14.00
19.00	99.00	56.00	4.95	14.00
20.00	99.00	62.00	4.95	14.00
21.00	99.00	62.00	4.95	14.00
22.00	99.00	62.00	4.95	14.00
23.00	99.00	62.00	4.95	14.00
24.00	99.00	62.00	4.95	14.00
25.00	99.00	67.00	4.95	14.00
26.00	99.00	67.00	4.95	14.00
27.00	99.00	67.00	4.95	14.00
28.00	99.00	67.00	4.95	14.00
29.00	99.00	67.00	4.95	14.00

30.00	99.00	62.00	4.95	14.00
34.00	99.00	62.00	4.95	14.00
35.00	99.00	58.00	4.95	14.00
36.00	99.00	58.00	0.00	0.00
37.00	99.00	58.00	0.00	0.00
38.00	99.00	58.00	0.00	0.00
39.00	99.00	58.00	0.00	0.00
40.00	99.00	56.00	0.00	0.00
41.00	99.00	56.00	0.00	0.00
42.00	99.00	56.00	0.00	0.00
43.00	99.00	56.00	0.00	0.00
44.00	99.00	56.00	0.00	0.00
45.00	99.00	54.00	0.00	0.00
46.00	99.00	54.00	0.00	0.00
47.00	99.00	54.00	0.00	0.00
48.00	99.00	54.00	0.00	0.00
49.00	99.00	54.00	0.00	0.00
50.00	99.00	56.00	0.00	0.00
51.00	-32767.00	-32767.00	1.11	-32767.00
52.00	-32767.00	-32767.00	1.11	-32767.00
53.00	-32767.00	-32767.00	1.11	-32767.00
54.00	-32767.00	-32767.00	4.93	-32767.00
60.00	-32767.00	-32766.00	4.54	13.00
61.00	-32767.00	-32766.00	4.54	13.00
62.00	-32767.00	-32766.00	4.54	13.00
63.00	-32767.00	-32766.00	4.54	13.00
64.00	-32767.00	-32766.00	4.54	13.00
65.00	-32767.00	-32766.00	5.00	12.00
66.00	-32767.00	-32766.00	5.00	12.00
67.00	-32767.00	-32766.00	5.00	12.00
68.00	-32767.00	-32766.00	5.00	12.00
69.00	-32767.00	-32766.00	5.04	12.00
70.00	-32767.00	-32766.00	5.04	12.00
71.00	-32767.00	-32766.00	5.04	12.00
72.00	-32767.00	-32766.00	5.04	12.00
73.00	-32767.00	-32766.00	5.12	13.00
74.00	-32767.00	-32766.00	5.12	13.00
75.00	-32767.00	-32766.00	5.12	13.00
76.00	99.00	71.00	5.12	13.00
77.00	99.00	71.00	5.25	13.00
78.00	99.00	71.00	5.25	13.00
79.00	99.00	71.00	5.25	13.00
80.00	99.50	68.00	5.25	13.00
81.00	-32767.00	-32767.00	5.25	13.00
82.00	-32767.00	-32767.00	4.93	13.00

86.00	-32767.00	-32766.00	5.39	13.00
87.00	-32767.00	-32766.00	5.39	13.00
88.00	-32767.00	-32766.00	5.39	13.00
89.00	-32767.00	-32766.00	5.39	13.00
90.00	-32767.00	-32767.00	5.34	13.00
91.00	-32767.00	-32767.00	5.34	13.00
92.00	-32767.00	-32767.00	5.34	13.00
93.00	-32767.00	-32767.00	5.34	13.00
94.00	-32767.00	-32767.00	5.36	14.00
95.00	-32767.00	-32766.00	5.36	14.00
96.00	-32767.00	-32766.00	5.36	14.00
97.00	-32767.00	-32766.00	5.36	14.00
98.00	-32767.00	-32766.00	5.28	14.00

APPENDIX C: Plug-ins

The S/5 Collect includes a number of plug-in examples. The S/5 Collect will recognize all LabVIEW 6.1 Virtual Instrument files (*.vi) with the below type definition. A plug-in is called by default each 500 ms offline. You can change the interval in online mode for the selected plug-in. The minimum rate is 50 ms. The data passed to the plug-in is trend and wave data including the configuration data.

The directory \plugins under the installation path contains examples of plug-ins.

To design your own plug-in, copy the example file `Your Project.vi` to a new file and modify it using LabVIEW version 6.1 to include your specific parameters and your specific user interface.

An example of how additional calculations can be done on trended parameters is included in the file `Calculation.vi`.

If your LabVIEW project contains a main Virtual Instrument (.vi) that calls other sub-vi's, do as follows:

1. Store your entire project to the plug-in directory used by S/5 Collect in LabVIEW by selecting **File - Save with options - Development Distribution** and clicking **Include vi.lib files**.
2. Open the .lib file with the LabVIEW VI Library manager and copy the main .vi to the plug-in directory used by S/5 Collect.
3. Delete the file with the name of the main .vi from the library.

NOTE: If more projects are stored in the same subdirectory, all .vi names that appear in multiple libraries must be identical to each other.

An example of how algorithms in a .dll file generated with Microsoft Visual C++ can be linked to a LabVIEW Virtual Instrument plug-in is included in file `S5 DLL Call.vi`. For more information on how to make a .dll, see the National Instruments web site www.ni.com and select **NI Developer Zone - Development Library - Measurement and Automation Software - LabVIEW - Development System - Communicating with External Applications - Using External Code - Integrating DLLs : How to Build a DLL with Visual C++**.

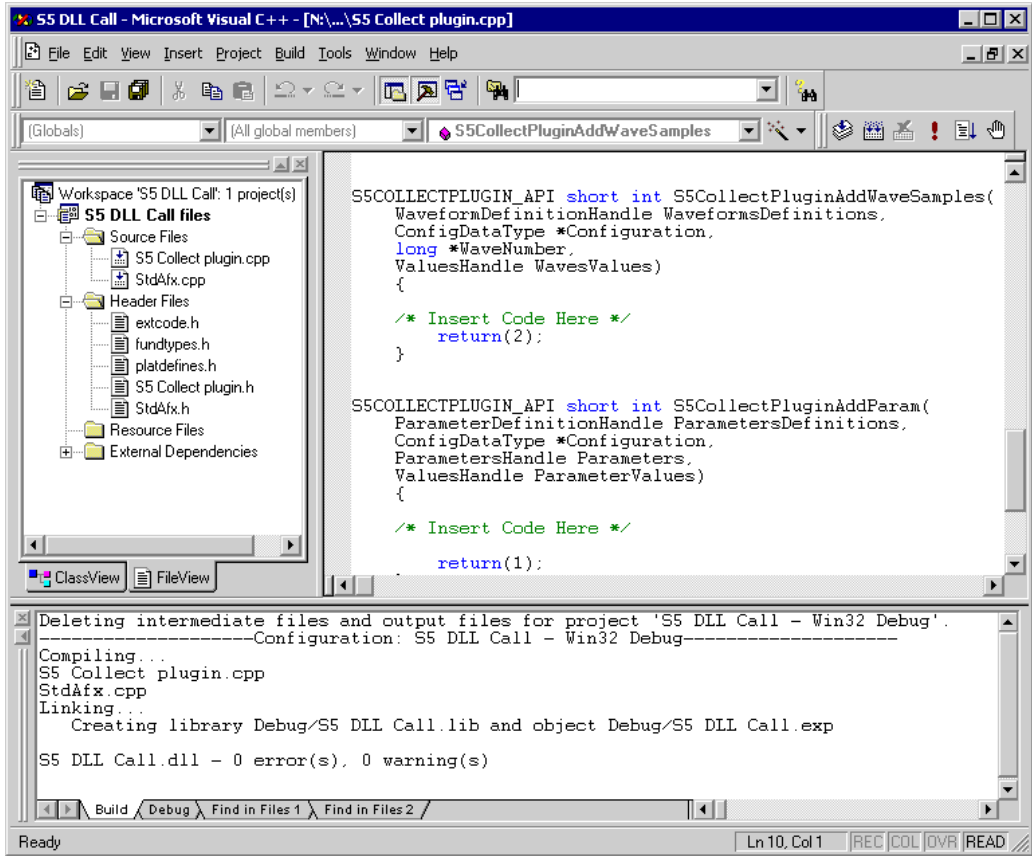

All C++ source files that are needed to regenerate a .dll file are copied in the plug-in directory.

When running the .vi under S/5 Collect it is possible to resize the online and offline windows to make sufficient room to display the plug-in, while maintaining full control over the icons and menus of the Online and Offline windows.

Your Project.vi

Connector Pane

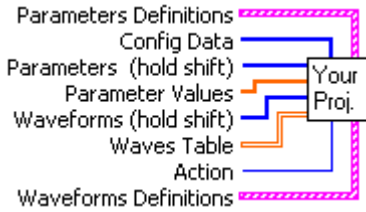

Front Panel

The front panel features a main graph area with a y-axis ranging from -5 to 30. Below the graph is a control bar with a dropdown menu set to "InvasiveP4", a display showing "Heart_Rate" with a value of "0.00", and buttons for "Clear" and "Return".

Below the control bar are several configuration sections:

- Action:** A dropdown menu set to "Init".
- Config Data:** A numeric control set to 0.
- Parameters (hold shift):** A list box containing "Heart_Ra", "Lead1STL", "Lead2STL", "Lead3STL", "Impedanc", "P1Systolic", "P1Diastoli", "P1Mean", and "Pleth".
- Waveforms (hold shift):** A list box containing "None", "ECG1", "ECG2", "ECG3", "P1", "P2", "P3", "P4", and "Pleth".
- Waves Table:** A table with 4 columns and 4 rows of numeric controls, all set to 0.00.
- Configuration Data:** A panel with "Trend Time" (02:00:00, 01/01/19), "Trend Number" (0), "Wave Time" (02:00:00, 01/01/19), "Wave Number" (0), and "Wave to Trend Delay (ms)" (0).
- Waveforms Definitions:** A control for "P2" with units "mmHg", name "InvasiveP2", and values 100, 100, 0, 0.
- Parameters Definitions:** A control for "P5mean" with units "mmHg", name "P5Mean", and values 0, 125, 100.
- Parameter Values:** A vertical stack of five numeric controls, all set to 0.00.

Controls and Indicators

U16 **Action** Possible actions :

0=Init : When opening the online or offline view or after selecting a new plug-in

During init at opening of the online or offline windows only **Parameters**, **Parameters Definitions** and **Waveform Definitions** are valid. All the other input parameters are equal to zero.

1=Process : In the online window called each 500 ms (default) or at the interval indicated in the Plug-in selection window.

In the offline window called each time a new package has been read from file. Note that duplicate data may arrive in the plug-in. The Configuration data date-time stamp could be checked to see if the new package is the same as in the previous call. Alternatively the latest datex_hdr_rd could be checked to see what the latest updated package has been before the plug-in call.

During process all input variables contain valid data.

2=Exit :When exiting the online or offline window the plug-in will be called with the Exit action. This may be used to save latest data and close the plug-in view.

3=View :In the offline window called each 500 ms (default)or at the interval indicated in the Plug-in selection window. During view none of the other input variables contain valid data.

Parameter Values A list of single precision values in the order indicated in the Configuration Editor.

Parameters A list of references to positions in the parameters list indicated in black in the selection list on the online and offline view.

Waveforms A list of references to positions in the waves list indicated in black in the selection list in the online and offline view.

Waves Table

SGL Two-dimensional array of single precision values with for each row a list of the new samples of all selected waveforms from the last 2 seconds. The amount of columns depends on the **Frequency** defined in the online or offline window.

SFB **Waveforms Definitions** See section “[Editing the database configuration.](#)” Use this table to get all needed string constants for your plug-in.

SFB **Parameters Definitions** See section “[Editing the database configuration.](#)” Use this table to get all needed string constants for your plug-in.

SGL **Configuration Data** Includes

- Information needed to set time stamps to the received trend and waveform data.
- The latest package number of the last trend and wave package.
- The time difference between the trend and wave packages (wave packages are buffered for 3 seconds plus the maximum delay used in the Configuration window).

Block Diagram

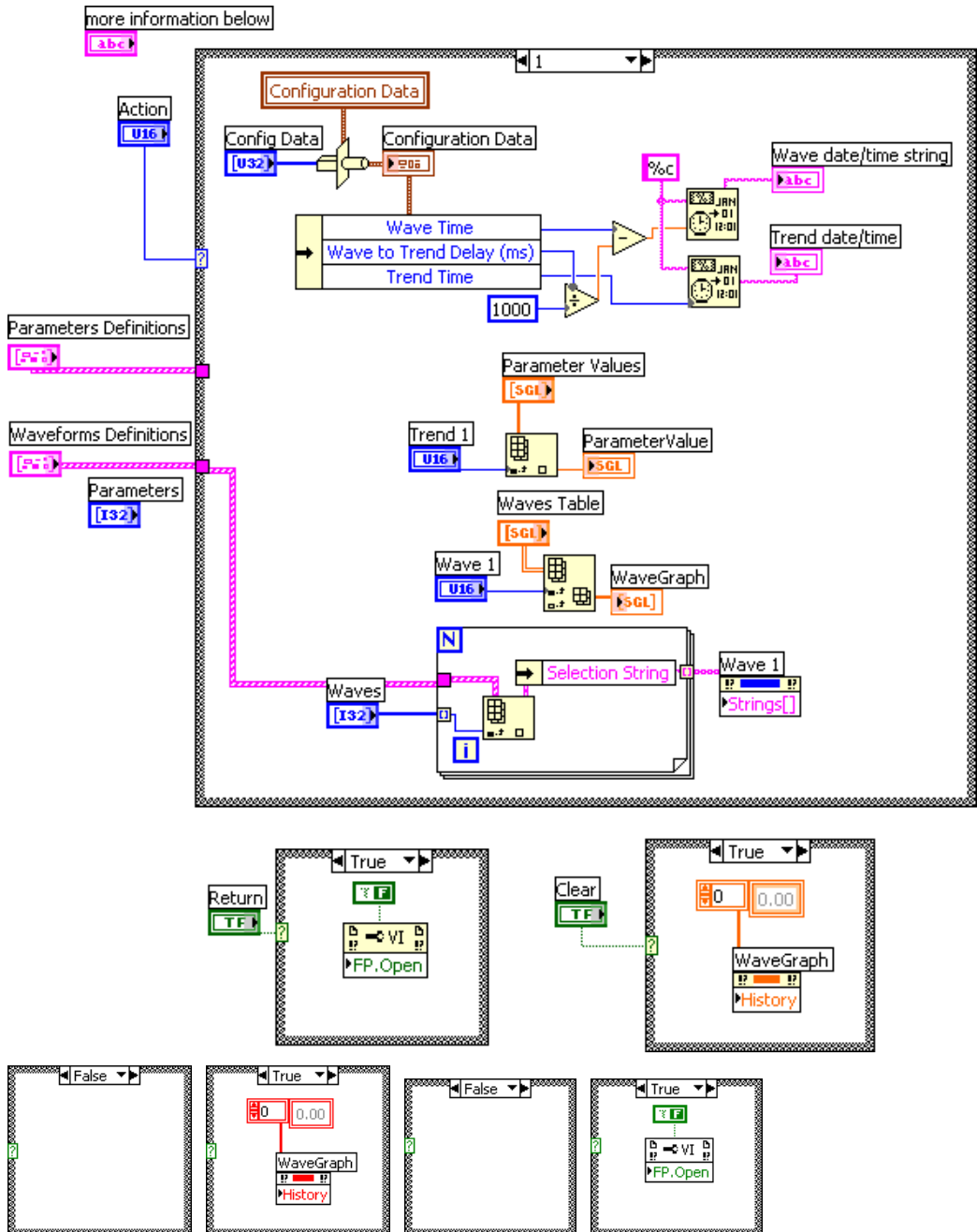

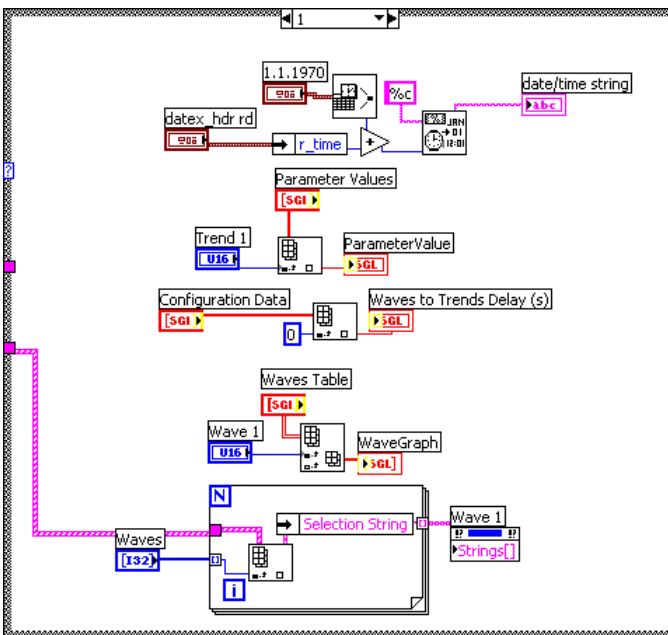
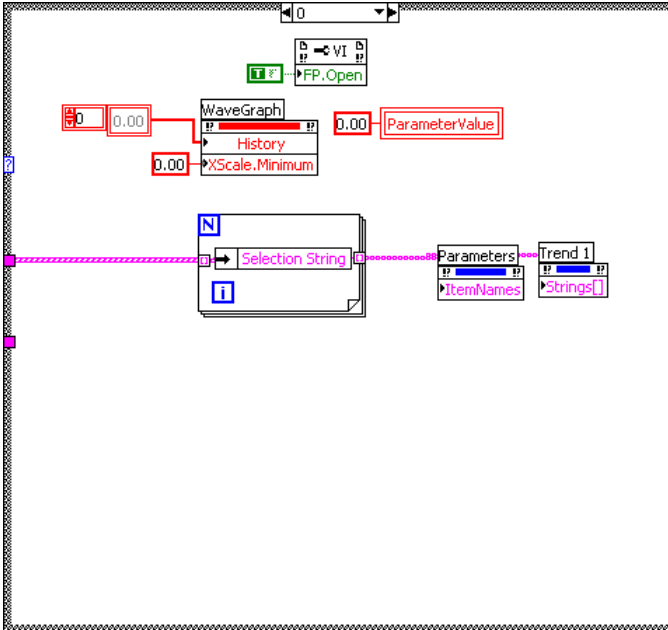

Index

A

Alarm IDs · B-11
Alarms
 displaying · 4-11
 saving in ASCII files · 4-13, 5-21
 saving in drc files · 4-12
Alarms.asc · B-9
All page · 4-16
ASCII button · 4-4, 4-13
ASCII files · 4-7, 4-13, 5-2, 5-15, 5-21
 decimal symbol · 4-13, 5-21
 output format · B-9
 saving data · 4-13, 5-2, 5-15, 5-21
 time format · 7-3
 total size · 4-13
 viewing · 5-22
ASCII output files · B-9
Auto Stop · 5-16
Auto Stop button · 5-5, 5-16
Autoselection of trends · 4-9, 5-9

C

C++ · 1-1, 2
Cancel button · 5-2, 5-15, 5-16
Clear button · 4-11, 5-4, 5-5, 5-7, 5-9, 5-12
Command buttons
 offline mode · 5-5
 online mode · 4-4
Communication buffer · 4-3, 4-8
 overload · 6-2
Compatible Datex-Ohmeda devices · 1-3

Configuration · 7-1
 defining the digit field color behavior · 7-3
 files · 1
 parameters · 7-2
 time format for ASCII files · 7-3
 waveforms · 7-2
Configuration Editor · 7-1
Context-sensitive help · 6-1
Convert button · 5-19
Cursor legend palette · 5-13, A-6

D

Data file size · 4-7
Database configuration · 7-1
Datex-Ohmeda S/5 Central · 4-1, 5-17
Datex-Ohmeda web site · 6-2
Decimal symbol in ASCII files · 4-13, 5-21
Digit field · 4-9, 5-9
 defining the color behavior · 7-3
 Trends page · 4-9, 5-9
Displaying alarms · 4-11
Displaying events · 4-12
DLL · 1-1, 4-27, 2
DRC button · 4-4, 4-12
Drc files · 4-12, 5-1, 5-20
 opening · 5-1
 opening a new · 5-22
 saving data · 4-12, 5-20
 selecting · 5-1
Dynamic Link Library · 4-27

E

Error messages · 6-3
Events
 displaying · 4-12
 saving in drc files · 4-12
Exiting the program · 3-8
Export trend records to PHY directory dialog ·
 5-20

F

Found. What next? dialog · 5-15
Freeze button · 4-4, 4-11

G

Go to time · 5-14
Go to time button · 5-5
Graph palette · A-5

H

Hardware requirements · 1-3
Help menu · 6-1

I

Installation · 3-1
IP address · 4-1

K

Key combinations · 6-1

L

LabVIEW · 4-26
 palettes · 4-21, 5-8, 5-13, A-1
LabVIEW editor · 4-26
Loading PHY files · 5-17

M

Manual
 about this manual · 1-2
 accessing through Start menu · 3-5
 displaying in pdf format · 6-1
 on CD-ROM · 1-2
Marker · 4-15
 searching · 5-17
Moving to a desired time · 5-14

N

NI LabVIEW RunTime Engine 6.1 · 4-26
Notes · 4-14, 5-23
 adding · 4-14
 adding markers · 4-15
 adding new to predefined · 4-15
 exporting to Excell · 4-15
 predefined · 4-14
 printing · 4-15
 removing contents · 4-15
 replacing the predefined · 4-15
Notes on usage · 2-1
Numerical parameter values · 4-9, 5-9
Numerics page · 4-22

O

- Offline main window · 5-3
- Offline mode
 - command buttons · 5-5
 - exiting · 5-23
 - replaying data · 5-5
 - starting · 5-1
 - times displayed on screen · 5-4
- One page · 4-19
- Online main window · 4-3
 - resizing · 4-4
- Online mode
 - command buttons · 4-4
 - exiting · 4-27
 - starting · 4-1
- Open drc file button · 5-5
- Overlaid page · 4-17

P

- Parameters
 - configuration · 7-2
- Params.txt · B-1
- Password · 3-7
- PCMCIA card · 5-17
- PHY files · 5-17
 - converting to drc format · 5-19
 - saving drc data into PHY files · 5-20
- Play data fast button · 5-5
- Play data slowly button · 5-5
- Plot Legend palette · A-1
- Plug-in · 4-26, 5-23, C-1
 - designing · C-1
 - examples · C-1
 - file location · 4-26
- Predefined notes · 4-14

Printing

- current snapshots · 4-21, 4-23
 - current window · 4-27
 - currently displayed data · 5-22
 - notes · 4-15
 - offline mode · 5-22
- Program version · 6-2

R

- Readme file · 1-2, 3-5
- Register button · 3-6
- Register window · 6-2
- Registration · 3-7, 4-13, 4-26, 5-21, 6-2
- Replaying data in offline mode · 5-5
- Resizing main window · 4-4
- RS232 communication buffer indicator bar · 6-2

S

- S/5 Collect · 1-1
 - exiting · 3-8
 - features · 1-1
 - installing · 3-1
 - offline mode · 5-1
 - online mode · 4-1
 - registering · 3-7
 - showing version and generation date · 6-2
 - version 4.0 · 3-1
- Safety precautions · 2-1
- Save All to ASCII button · 5-2, 5-22
- Save to ASCII button · 5-15
- Saving data in ASCII files · 4-13, 5-2, 5-15
 - saving all data · 5-22
 - saving selected data · 5-21
- Saving data in drc files · 4-12, 5-20
- Saving data in PHY files · 5-20

Scale Legend palette · A-3
Searching for markers · 5-17
Select Patient File dialog · 5-17, 5-18
Set Auto Stop Time button · 5-15
Set Time dialog · 5-14
Snapshot button · 5-5
Snapshots · 4-16, 5-22
 All page · 4-16
 exporting to ASCII · 4-24
 exporting to Excel · 4-24
 Numerics page · 4-22
 One page · 4-19
 Overlaid page · 4-17
 printing currently displayed · 4-21, 4-23
 using snapshot data in Excel · 4-24
 working with graphical · 4-20
 working with numerical · 4-22
Software requirements · 1-3
Start Play button · 5-2, 5-15
Start reading from beginning button · 5-5
Startup · 3-5
 network communication · 4-1
 offline mode · 5-1
 online mode · 4-1
 serial communication · 4-1
Stop button · 4-4, 4-12, 4-13, 5-2, 5-5
Stopping an action · 5-16

T

TCP/IP network board · 4-1
Time format for ASCII files · 7-3
Trends
 autoselection · 4-9, 5-9
 clearing from screen · 4-11, 5-9
 configuration · 7-2
 freezing · 4-11

 latest numerical parameter value · 4-9, 5-9
 sampling interval · 4-10, 5-10
 saving in ASCII files · 4-13, 5-2
 saving selected in ASCII files · 5-21
 selecting displayed · 4-9, 5-9
 showing data as XY graphs · 5-11
 trend scale · 4-10, 5-10
Trends page · 4-8, 5-8
 digit field · 4-9, 5-9
Trends XY page · 5-11
Trends.asc · B-14
Typeface conventions · 1-2

U

Unexpected errors · 6-3

W

Waveforms
 clearing · 5-7
 configuration · 7-2
 freezing · 4-11
 period of waveform display · 4-7, 5-7
 sampling interval · 4-6, 5-7
 saving in ASCII files · 4-13, 5-2
 saving selected in ASCII files · 5-21
 selecting displayed · 4-6, 5-7
 showing data as XY graphs · 5-11
Waves page · 4-5, 5-6
Waves XY page · 5-11
Waves.asc · B-13
Waves.txt · B-7
Wind forward button · 5-5
Virtual Instrument · C-1
Virtual LabVIEW instrument · 4-26